

DHOLLANDIA

DH-RP.10

INSTALLATION MANUAL

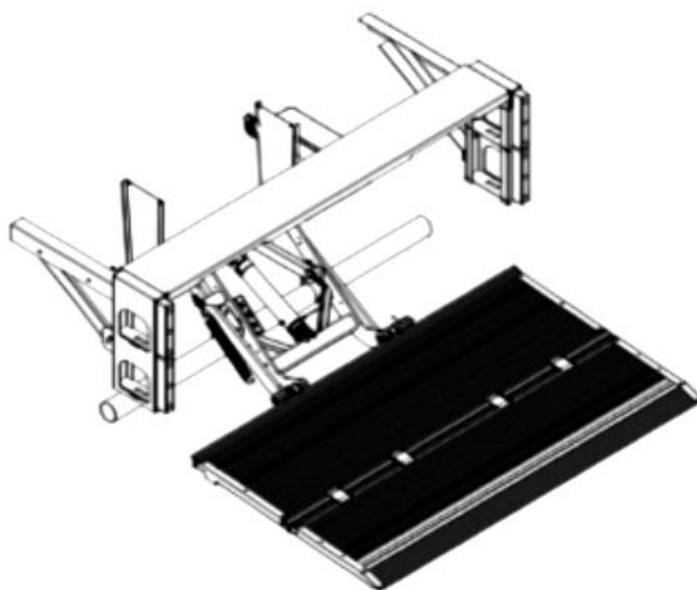

900-1000kg

** Pictured: RP.10 tail lift

Manufacturer:
DHOLLANDIA N.V. Zoomstraat 9 9160 LOKEREN (Belgium)
Tel : +32 (0)9 349 06 92 Fax : +32 (0)9 349 09 77
e-mail : info@dhollandia.be
website : www.dhollandia.com

Read the manual in its entirety before operating the tail lift

Keep this manual in the vehicle cab, as reference for the driver and tail lift operator

Contents

1	UNDERSTANDING SAFETY AND WARNING SIGNS.....	2
2	INTRODUCTION AND DISCLAIMERS	3
3	CONTACT INFORMATION	4
4	SAFETY PRECAUTIONS FOR OPERATION	5
5	SAFETY PRECAUTIONS FOR INSTALLATION	5
6	TAIL LIFT TERMINOLOGY	8
6.1	DH-RP.10 Tail lift terminology	8
6.2	Installation parameters terminology	10
6.3	Getting started.....	13
6.4	Installation dimensions	14
7	FLOOR EXTENSION PLATE AND CHASSIS CUT.....	17
8	MOUNTING OF THE EXTENSION PLATE	18
9	MOUNTING OF THE LIFT FRAME (premounted platform).....	21
10	FIXATION OF THE BOLT-ON MOUNTING PLATES.....	26
11	INSTALLATION OF CONTROL SWITCH.....	31
11.1	Mounting of the control switch.....	31
11.2	Connection block terminology	34
11.3	Gravity down wiring for the control switch	35
11.4	Power down wiring for the control switch	37
12	CONNECTION TO THE BATTERIES.....	39
13	PUTTING THE TAIL LIFT INTO SERVICE.....	41
14	PLATFORM ORIENTATION.....	43
15	MOUNTING OF THE SIDE STEPS & DOCK BUMPERS.....	44
16	LUBRICATION INSTRUCTIONS.....	48
17	COMMISIONING & QUALITY CONTROL	50
18	DECALS	51
18.1	Regular decals	51
18.2	Identification decals.....	54
19	APPENDIX.....	55
19.1	Decals	55
19.2	Prescribed torques values for bolts supplied with tail lift	57
19.3	PDI checklist 1/2.....	59
19.4	Safe operator position on the platform	62
19.5	2-button portable control	63
19.6	Circuit breaker	69
19.7	Cab cut off switch	70
19.8	Electric and hydraulic Information	71
19.9	End note.....	73

1 UNDERSTANDING SAFETY AND WARNING SIGNS

- Many safety signs and symbols used in this manual are based on international standards, others refer to specific situations or actions.
- Consult Appendix 1 for an overview of signs and symbols used in DHOLLANDIA manuals, and their meaning. Make sure you understand these signs and symbols prior to starting the installation.

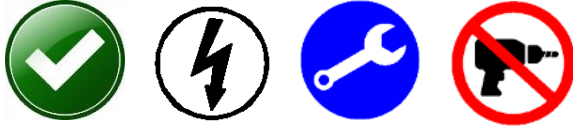
Examples of standard ANSI signs	
Examples of DHOLLANDIA purpose made signs	

- Please take special notice of the following signs used in the manual. They indicate the likelihood and severity of a potential injury if a person fails to follow the instructions presented on the safety sign.



DANGER: indicates an imminently hazardous situation which, if not avoided, will result in death or serious injury. [white letters on red background]



WARNING: indicates a potentially hazardous situation which, if not avoided, could result in death or serious injury. [black letters on orange background]



CAUTION: indicates a potentially hazardous situation which, if not avoided, could result in minor or moderate injury. [black letters on yellow background]



NOTICE: is used to address practices not related to physical injury. [white letters on blue background]



SAFETY INSTRUCTIONS: indicate general instructions relative to safe work practices, reminders of proper safety procedures, or the location of safety equipment. [white letters on green background]



SAFETY ALERT SYMBOL: is used to alert the user to potential hazards. All safety messages that accompany this sign shall be obeyed to avoid possible harm. [free-standing, or on background colours red, orange, yellow or black]





WARNING

- Failure to understand and to follow the instructions in this manual can put the operator and any bystanders at great risk of serious bodily injury and death.
- Prior to operating the tail lift, make sure you understand the safety and warning signs used, and read them in conjunction with the instructions in this manual.
- If in doubt, DO NOT operate the tail lift. Contact your national DHOLLANDIA distributor. See page 4 for contact info.

2 INTRODUCTION AND DISCLAIMERS

- This manual provides you with the information necessary for the installation of the DHOLLANDIA DH-RP.10 fold-away tail lift.
- It provides you with general instructions applicable to the common truck and trailer types. It might be possible that specific issues particular to your installation case are not adequately covered by this manual. If in doubt, please contact your local DHOLLANDIA distributor for further assistance.
- The CE IDENTIFICATION AND INSPECTION BOOK (separate) contains the serial number identification, the CE Declaration of Conformity, the Fitting Declaration to be filled out by the installer of the tail lift, and an overview of the owner's legal obligations in terms of periodic testing and certification.



WARNING

- Improper installation can cause damage to the tail lift, can reduce the durability and reliability of the tail lift, and can put the operator and bystanders at great risk of serious bodily injury and death in many ways.
- It is therefore essential that the tail lifts are installed with proper care, in compliance with the installation instructions of this manual.
- In case of doubt, ALWAYS contact the national DHOLLANDIA distributor for further advice, prior to continuing.

- DHOLLANDIA tail lifts are regularly being adapted to new vehicle and chassis developments, and specialized customer requirements. Therefore, DHOLLANDIA reserves the right to alter product specifications without prior notice. Such modifications might not have been included at the time this manual was printed.

NOTICE

- Please confirm you have reviewed the most up-to-date version of this manual prior to installation and operation of the associated DHOLLANDIA tail lift.
- It is the sole responsibility of the installer(s) to follow shop best practices for safety and craftsmanship and to use good common sense.

- Contact your national DHOLLANDIA distributor if you have any questions regarding the installation, operation, repair and maintenance of DHOLLANDIA tail lifts, or to obtain replacement copies of manuals or decals.

3 CONTACT INFORMATION

DHOLLANDIA tail lifts are regularly being adapted to new vehicle and chassis developments, and specialized customer requirements. Therefore, DHOLLANDIA reserves the right to alter product specifications without prior notice; and potentially modifications or new developments might not have been taken into account at the time of printing

NOTICE

Please confirm you have reviewed the most up-to-date version of this manual prior to operation of the associated DHOLLANDIA tail lift. See below for instructions to download the latest version of the manual.

Contact your national DHOLLANDIA distributor if you have any questions regarding the installation, operation, repair and maintenance of DHOLLANDIA tail lifts, to obtain replacement copies of manuals or decals, or to learn about available equipment options for DHOLLANDIA tail lifts.



If in doubt where to find your national DHOLLANDIA distributor, visit the official DHOLLANDIA website
www.dhollandia.com → **Country selection / language selection** → **Service and international work**



The latest version of all manuals can also be downloaded from the DHOLLANDIA website
www.dhollandia.com → **Downloads** → **User's manuals** → ... **select required manual**

- Take notice of following important disclaimers:

DISCLAIMERS

- DHOLLANDIA disclaims liability for any personal injury, death, or property damage that results from **operating a tail lift that has been modified from the original design**, without explicit written approval from the manufacturer.
- DHOLLANDIA disclaims liability for any personal injury, death, or property damage that results from **use of aftermarket or non-OEM replacement parts for service or repair of the tail lift**.
- DHOLLANDIA disclaims liability for any personal injury, death, or property damage that results from **improper use of the tail lift**.
- DHOLLANDIA disclaims liability for any personal injury, death, or property damage that results from **overloading or improperly loading the platform**, disregard of the maximum rated lift capacity and the applicable load charts.
- There are no warranties, express or implied, including the warranty of merchantability or a warranty of fitness for a particular purpose extending beyond that set forth in this manual.

4 SAFETY PRECAUTIONS FOR OPERATION



- It is essential that the personnel involved in installing, servicing and repairing tail lifts knows, understands and applies the safety instructions and precautions contained in the OPERATION MANUAL issued with the tail lift.
- Therefore, make sure you consult the OPERATION MANUAL prior to installing or operating the tail lift.

WARNING

- Improper use of the tail lift will put the operator and other parties at great risk of serious bodily injury and death.
- To reduce the risk of serious bodily injury to the operator and any bystanders, the use of the tail lift is restricted to skilled operators, who have been properly trained, and who know and understand the full contents of the operation manual.
- To reduce the risk of serious bodily injury or death, THE OPERATOR MUST COMPLY WITH ALL SAFETY INSTRUCTIONS AND WARNING LABELS IN THE OPERATION MANUAL before and while operating the tail lift.
- Please confirm you have reviewed the most up-to-date version of this manual prior to installation and operation of the associated DHOLLANDIA tail lift.

5 SAFETY PRECAUTIONS FOR INSTALLATION



- It is essential that the personnel involved in installing, servicing and repairing tail lifts knows, understands and applies the safety instructions and precautions contained in the GENERAL SAFETY INSTRUCTIONS FOR INSTALLATION, MAINTENANCE AND REPAIR manual.

- Therefore, make sure you consult the GENERAL SAFETY INSTRUCTIONS FOR INSTALLATION, MAINTENANCE AND REPAIR manual prior to installing the tail lift.

- These instructions are supplied as a separate manual with your tail lift.

- You can also contact the national DHOLLANDIA distributor for the latest edition of this manual. See page 4 for contact info. Or download the latest edition from the website:



www.dhollandia.com → your language → Downloads → User's manuals → General information

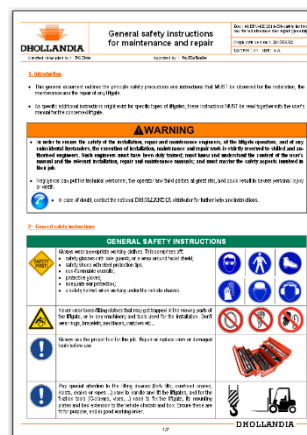
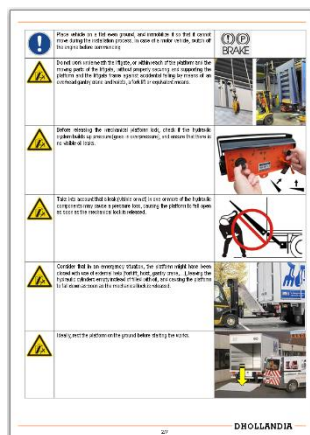

WARNING

- The personnel involved in tail lift installation are exposed to various dangers. Improper use of the tail lift, or ignorance and neglect during installation, will put the personnel at great risk of bodily injury and death.
- Improper installation can cause damage to the tail lift, can reduce the durability and reliability of the tail lift, and can put the operator and bystanders at great risk of serious bodily injury and death in many ways.
- To reduce the risk of serious bodily injury or death to the installation personnel, to the operator, and any bystanders, tail lift installation works MUST be restricted to skilled and trained technicians, who have been duly and professionally trained, and know, understand and apply the manuals of the tail lift:
 1. OPERATION MANUAL
 2. INSTALLATION MANUAL
 3. GENERAL SAFETY INSTRUCTIONS FOR INSTALLATION, MAINTENANCE AND REPAIR
- ALWAYS confirm you have reviewed the most up-to-date version of these manuals prior to installation and operation of the associated DHOLLANDIA tail lift.
- In case of doubt, ALWAYS contact the national DHOLLANDIA distributor for further advice, prior to continuing.
- ALWAYS wear appropriate Personal Protective Equipment. This includes but may not be limited to: ANSI rated glasses with side guards, or a wrap-around face shield; steel toe safety shoes; fire-resistant overalls; protective gloves; adequate ear protection; a safety helmet when working under the vehicle chassis.



- NEVER wear loose-fitting clothes that may get trapped in the moving parts of the tail lift, or in any machinery and tools used for the installation. Don't wear rings, bracelets, necklaces, watches etc...
- ALWAYS use the proper tool for the job. Repair or replace worn or damaged tools before use.
- Pay special attention to the lifting devices (forklifts, overhead cranes, hoists, chains or ropes...) used to handle the tail lifts, and for the clamping tools (C-clamps, pipe clamps, vise grips,...) used to clamp the tail lift, its mounting plates and floor extension to the vehicle chassis and box. Ensure these tools are appropriate for the job, and in good working order.
- Place the vehicle on a flat even ground and chock the wheels so that it cannot move during the installation process. In case of a motor vehicle, make sure the engine is off and the parking brake is set before starting.
- Do not work underneath the tail lift, or within reach of the platform and the moving parts of the tail lift, without properly securing and supporting the platform and the tail lift frame against accidental falling. Use an overhead crane and hoists, a forklift or equivalent means to secure the heavy tail lift components.
- Make sure the vehicle battery power is disconnected while installing the tail lift. Connect the battery power to the tail lift only when the installation is completed, or as required in the installation instructions.



- Before welding, note that welding on galvanized parts releases hazardous fumes. Provide adequate ventilation, and wear an appropriate toxic fume rated welding respirator.

- NEVER modify DHOLLANDIA tail lifts or their mounting plates without prior written consent by the manufacturer.



- If for any reason, trouble-shooting and / or repair might be needed during the installation process, consult and follow the guidelines and safety instructions of the MAINTENANCE MANUAL.

NOTICE

- Make sure the vehicle battery power is disconnected while installing the tail lift. Connect the battery power to the tail lift only when the installation is completed, or as required in the installation instructions.
- Except for the support channels and bracing of the side steps, which are usually welded to the cross members of the auxiliary chassis, **DHOLLANDIA tail lifts are designed as a bolt-on system, and don't require any welding. See Appendix 2 for prescribed torque values.**
- Welding should be done by qualified personnel only, and only to the extent allowed by the vehicle manufacturer. Ensure that the positive and ground cables are disconnected from the batteries, and that all vehicle electrical and electronic equipment is fully isolated before welding.
- ALWAYS keep the ground clamp as close as possible to the weld location.



WARNING

- NEVER modify DHOLLANDIA tail lifts or their mounting plates, NEVER deviate from the described installation procedures without prior written consent by the manufacturer.
- DHOLLANDIA disclaims liability for any personal injury and / or property damage that results from improper use.

6 TAIL LIFT TERMINOLOGY

6.1 DH-RP.10 TAIL LIFT TERMINOLOGY

See Figure 6.1 on next page for parts corresponding to numbers in this table

#	Description
1	Platform Assembly: combination of the main and flip sections of the platform.
2	Platform, Main Section: inboard section of the foldable platform. Manufactured from steel or lightweight aluminium, with a permanent non-slip working surface.
3	Platform, Flip Section: carries the load during loading / unloading, lifting / lowering. Consists of a platform main section and a flip-over point.
4	Platform Pitch Adjustment bolts: bolts that adjust the angle of the main and flip section of the platform.
5	Lift Arm Weldment: support brace between the parallel lift arms.
6	Parallel Arms: two parallel arms supporting the platform while it travels up and down.
7	Platform Opener: arm with roller(s) mounted on the lift frame, assisting the deployment of the platform from its travel position to the work position, then back to its travel position.
8	Lifting Cylinder: hydraulic cylinders used to LIFT / LOWER the lift arms, the platform and its load.
9	Mounting Plates: used to mount the lift frame to the vehicle chassis.
10	Bed Extension Plate: heavy duty steel extension mounted to the rear sill of the vehicle floor, with a permanent non-slip surface.
11	Side Steps: steps mounted to the side of the extension floor to help the driver climb into the vehicle from the side. The side steps incorporate rubber dock bumpers
12	Dock Bumpers: rubber buffers mounted on the rear face of the side steps, to reduce impact damage when the vehicle is reverting into a loading dock.
13	Support Channels: steel channels welded to the underside of the vehicle body (to the rear sill and support cross members underneath the vehicle floor).
14	Diagonal Braces: steel profiles linking the side steps and dock bumper with the support channels welded to the underside of the vehicle body. The construction with support channels and diagonal braces aims to distribute the forces of a dock impact over the rear sill and support cross members of the vehicle body and avoid damage as much as possible.
15	Bumper Bar: under run protection device.
16	Hydraulic Power Unit: contains the electric motor driving the hydraulic pump, the oil tank, and the control valves.

17	Toggle Control Switch: easy-to-use controls to LIFT/LOWER the platform, mostly mounted in fixed position at the side of the vehicle body, or on the rear post of the body.
18	Centre point of maximum load: point up to which the maximum rated capacity of the tail lift is valid. Beyond that point, the maximum safe working load diminishes according to the applicable load charts.

Figure 6.1

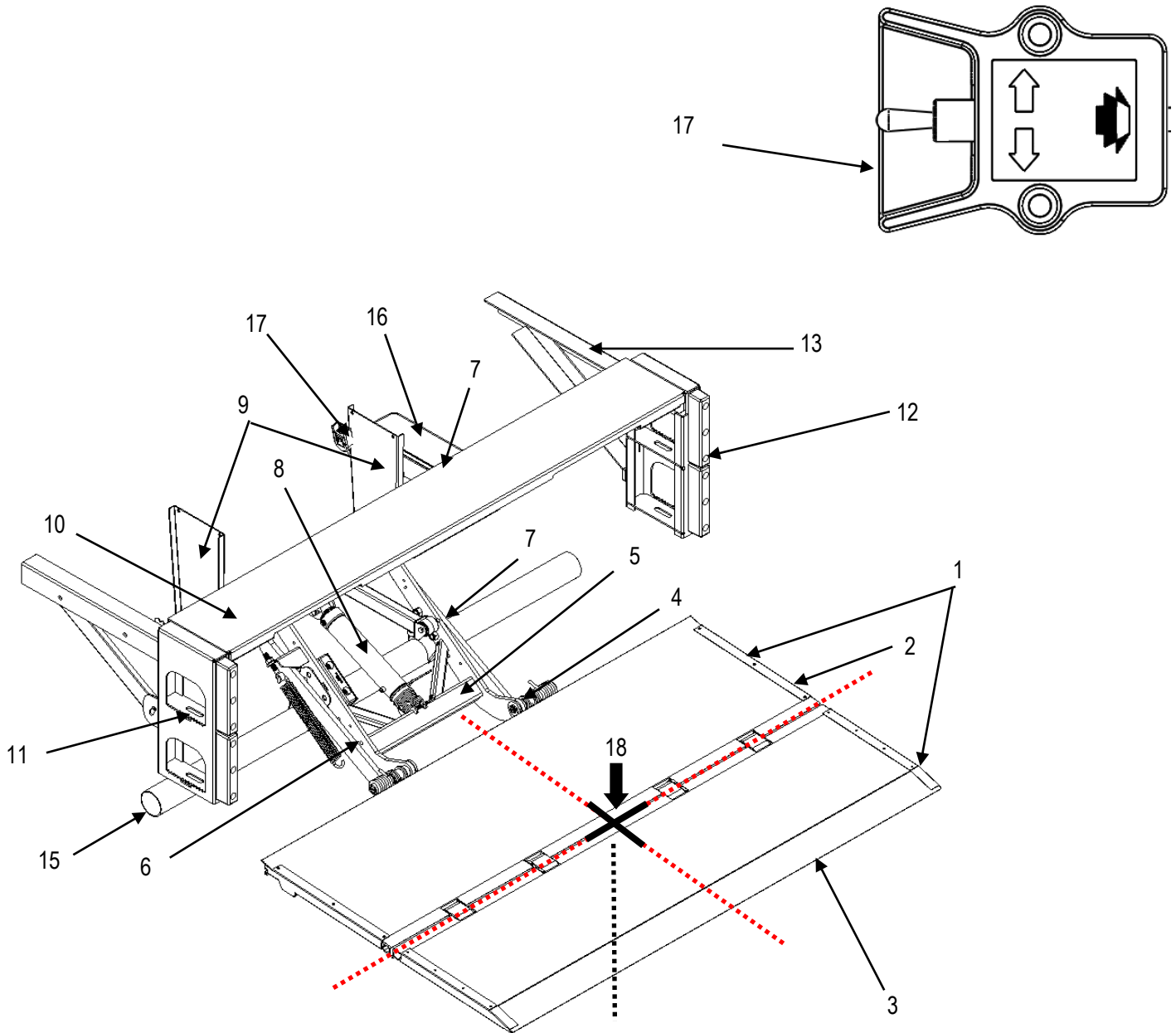

6.2 INSTALLATION PARAMETERS TERMINOLOGY

See Figure 6.2 on next page for parts corresponding to numbers in this table:

LARM	Length of the lift arms [= Lift ARM length]
VFH max	Max. height of vehicle floor (UNLOADED), applicable for the given arm length [= Vehicle Floor Height]
VFH	Actual height of vehicle floor (UNLOADED)
VFH min	Min. height of vehicle floor (FULLY LOADED)
CTH max	Max. height from underside of chassis to top of the vehicle floor, applicable for the given arm length [= Chassis Total Height]
CTH	Actual height from underside of chassis to top of the vehicle floor
MFT	Mounting height of lift frame under the vehicle: measured from the top of vehicle floor to the top of the lift frame main tube [= Mounting height Floor to Tube of frame]
MTG	Mounting height of lift frame above the ground: measured from the top of the lift frame main tube to the ground [= Mounting height Tube of lift frame to Ground]
MPG	Ground clearance under tail lift [= Mounting clearance Plates to Ground]
PD	Maximum length of the main and foldable platform sections [= Platform Depth]
LOF	Required mounting space to end of lift frame [= Lift Overhang to Frame]
LOP	Required mounting space to end of premounted pump unit [= Lift Overhang to Pump unit]

Figure 6.2

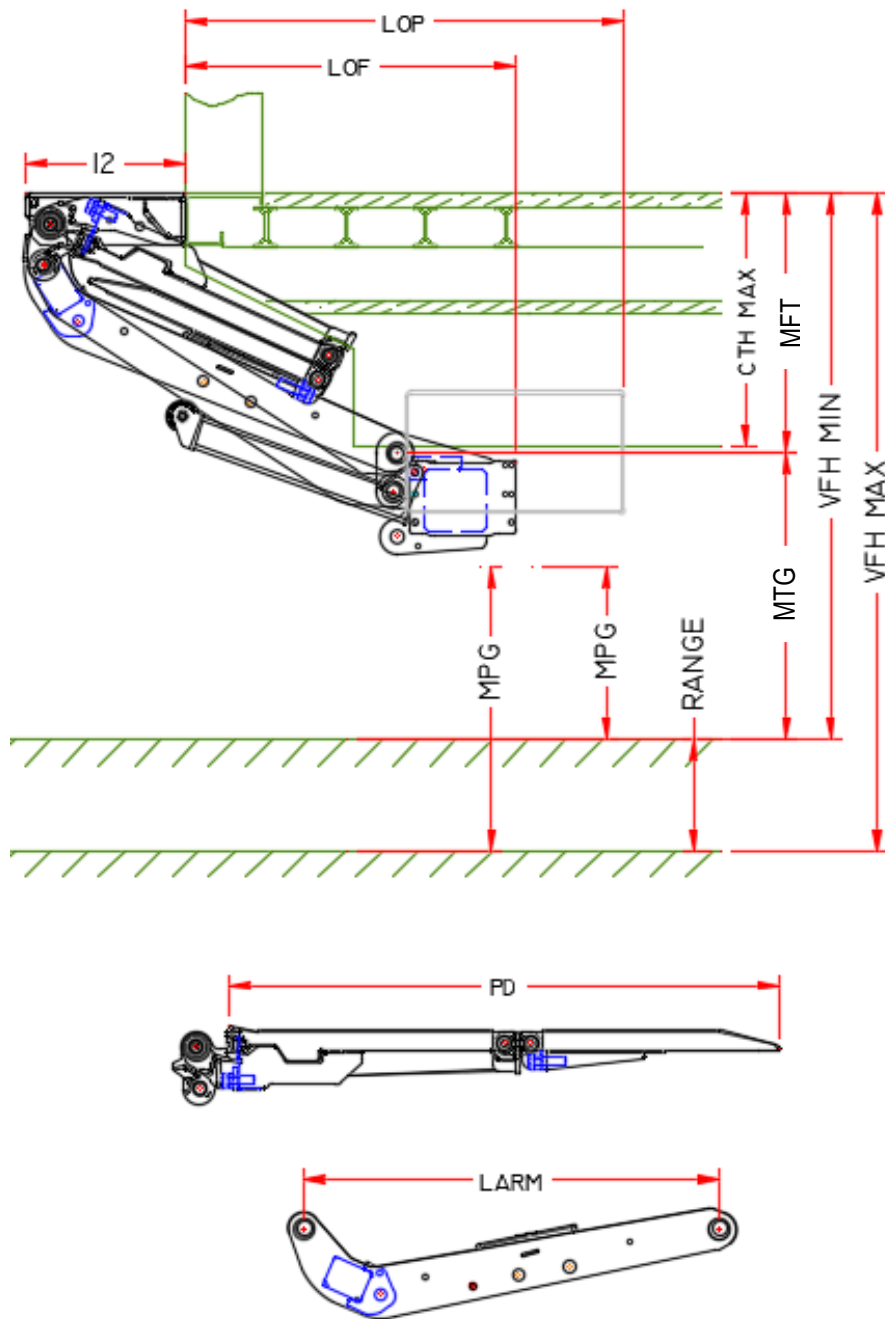

- See Figure 6.3 for parts corresponding to numbers in this table:

LAC	Width of the lift arms [= Lift Arm Centre]
CHW	Vehicle chassis width [= CH assis W idth]
BWO MIN	Min. body width with pump unit in premounted position [= B ody W idth O utside]

Figure 6.3

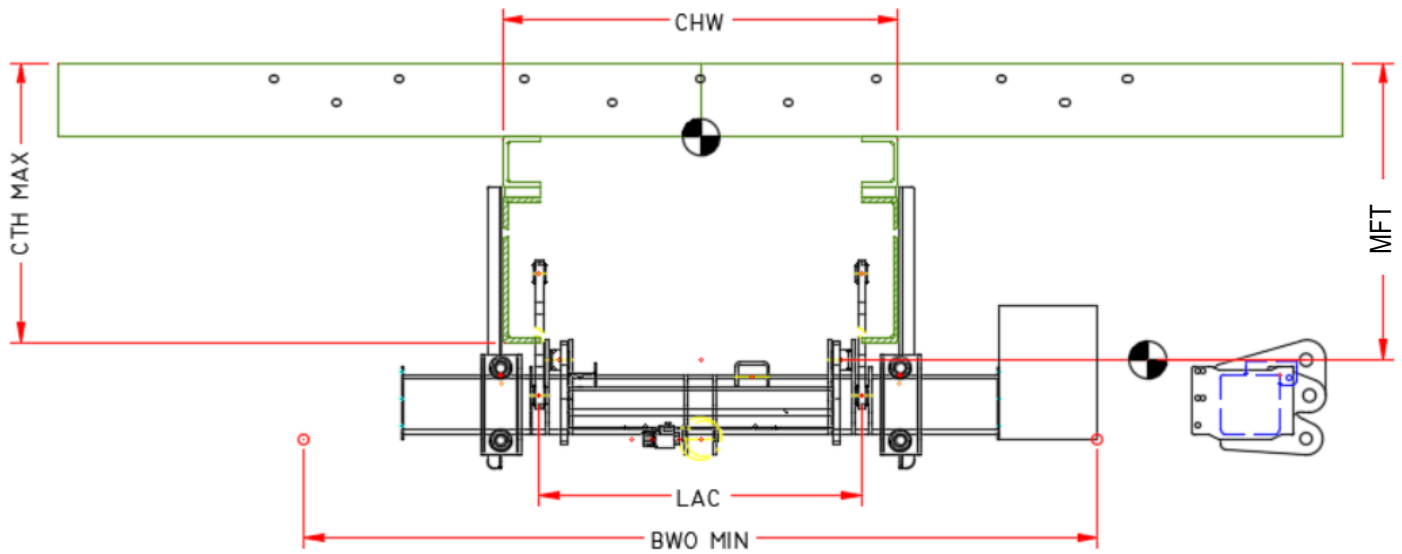

6.3 GETTING STARTED

- OEM Vehicle manufacturers may have issued important instructions on various aspects of the tail lift installation, specific to the brand and type of chassis, such as welding instructions (or prohibition to weld!); instructions on chassis drilling and bolt-on connections to the chassis; recommendations on the use of hydraulic stabilizing legs; guidelines for the battery and ground cable connections; fuses and other electrical interfaces; etc...

NOTICE

- **The installer MUST verify and ensure compatibility between the tail lift and the vehicle.**
- **The installer MUST verify and ensure compliance with the installation instructions issued by the vehicle and body manufacturer.**
- Improper modifications to the vehicle chassis or body could cause serious mechanical failure of the vehicle. The installer MUST ensure that modifications to the vehicle chassis and / or body will not adversely affect the structural integrity of the chassis and / or body.
- In the event instructions of vehicle manufacturer conflict with the installation instructions issued by DHOLLANDIA (e.g. on fuse ratings, etc.), contact your national DHOLLANDIA distributor for further assistance.
- In the event OEM instructions conflict with the installation instructions issued by DHOLLANDIA (e.g. fuse ratings, etc.) contact DHOLLANDIA US. See page 4 for contact info.

- Place vehicle on a flat even ground and chock the wheels so that it cannot move during the installation process. In case of a motor vehicle, switch off the engine and engage the parking brake before starting.
- Verify the installation kit is complete, and that all parts needed to correctly fit the tail lift are present.
- Compare the voltage of the vehicle batteries with the voltage of the hydraulic pump unit of the tail lift.
- Compare the installation dimensions and maximum installation parameters indicated in the installation drawing with the actual dimensions of the vehicle, to verify compliance. (See next chapter).
- Verify if the vehicle chassis and body are strong enough to support the load and moment created by the tail lift at maximum rated capacity. Refer to the Body Builder Guidelines of the OEM vehicle manufacturer for details.
- Check the stability of the vehicle and the weight over the axles with the addition of a tail lift loaded to maximum capacity. The weights indicated in the technical documentation and price list are theoretical and approximate and may vary from one tail lift installation to another.
- Make sure that the body is accurately fitted to the vehicle chassis.
- Remove all objects that are mounted in the mounting space required by the tail lift (RUP, spare wheel carrier, pallet racks, tool boxes, etc.). If necessary, consult with the OEM vehicle manufacturer for replacement solutions (e.g. special spare wheel carriers, exhaust pipe modifications, etc.).
- Finish the tail lift in compliance with applicable road legislation of the country where the vehicle will be registered.
- When connecting hydraulic fittings, make sure that the connections are thoroughly clean, and that you don't contaminate the hydraulic oil.
- Grease all bearings and pins before putting the tail lift into service. It is recommended to grease all articulation bearings before mounting the corresponding articulation pin.
- After installation, work through the pre-delivery inspection (PDI) checklist, verify all check points with due diligence. Make sure the final inspection is signed off by an inspector who is not part of the installation team.

- Do not pressurize any tail lift functions (LIFT / LOWER) before the tail lift installation is fully finished.
- During installation and while testing, verify that the tail lift and its moving parts don't interfere with, or cause damage to the vehicle systems (e.g. to suspension, braking system, hydraulic and electrical circuits, etc.).

6.4 INSTALLATION DIMENSIONS

- The DH-RP10.02 are usually delivered with a premounted mounting bar between the lift arms and lift frame, pre-setting the mounting height $MFT = 445\text{mm}$. [Figure 6.4].

Figure 6.4 shows:

1. the required overhang LOF / LOP
 2. the min. vehicle floor height $VFH \text{ MIN.}$ and corresponding ground clearance MPG
 3. The max. vehicle floor height $VFH \text{ MAX.}$ and corresponding ground clearance MPG
- Before starting the installation, verify if the actual floor height VFH of the vehicle falls within the given min. and max. range $VFH \text{ MIN.} < VFH < VFH \text{ MAX.}$
 - The max. floor height $VFH \text{ MAX.}$ should be measured for an **UNLOADED** vehicle (= worst case)
 - The min. floor height $VFH \text{ MIN.}$ should be measured for a **FULLY LOADED** vehicle (= worst case)

Figure 6.4

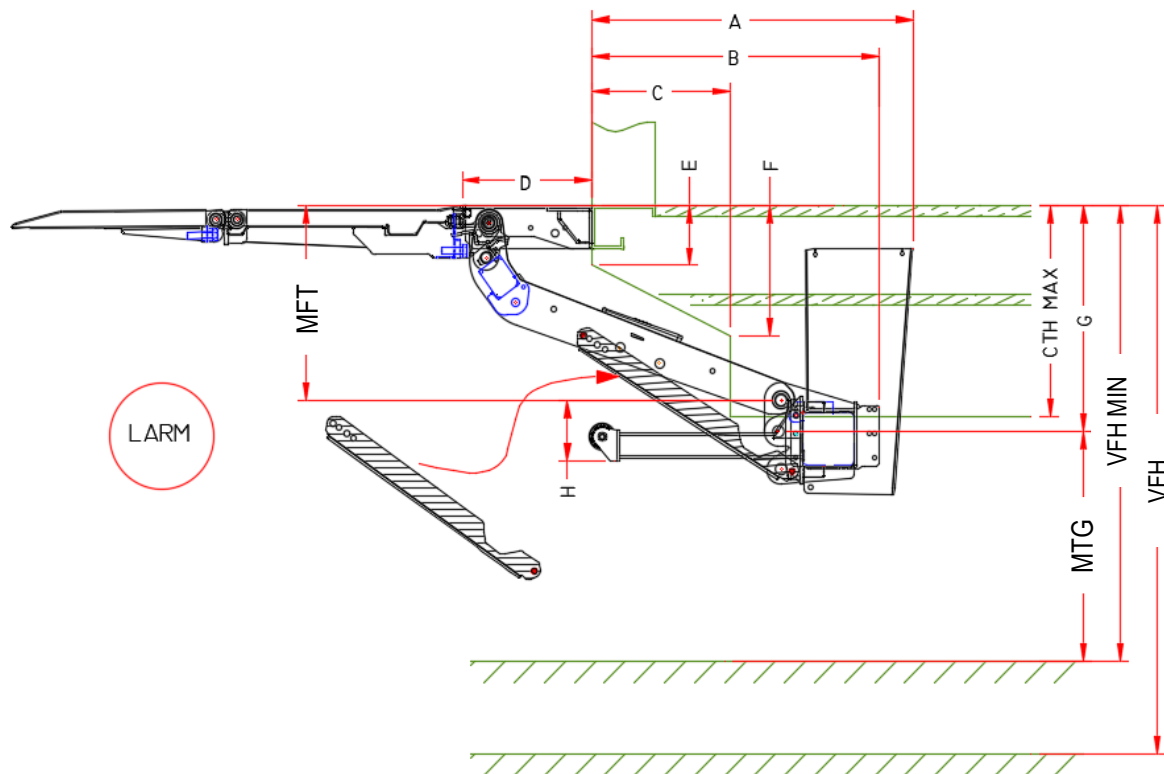

Dimensions table	
	mm
A	756
B	667
C	330
D	305
E	140
F	298
G	521
H	140
MFT	445
CTH MAX	457
MTG	673
VFH MAX (42" platform)	1120
VFH MIN (42" platform)*	970
VFH MAX (50" platform)	1170
VFH MIN (50" platform)	970
LARM	800

*if bed height is below 960mm – set lock bar at 567mm. The VFH MIN. is now 860mm – only for 1060mm platform.

Figure 6.5

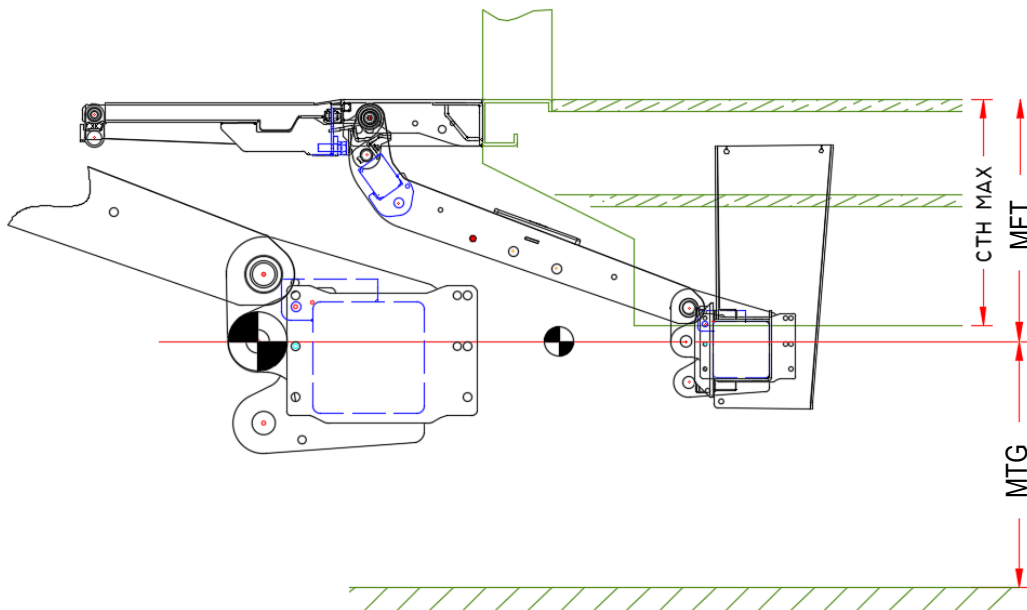
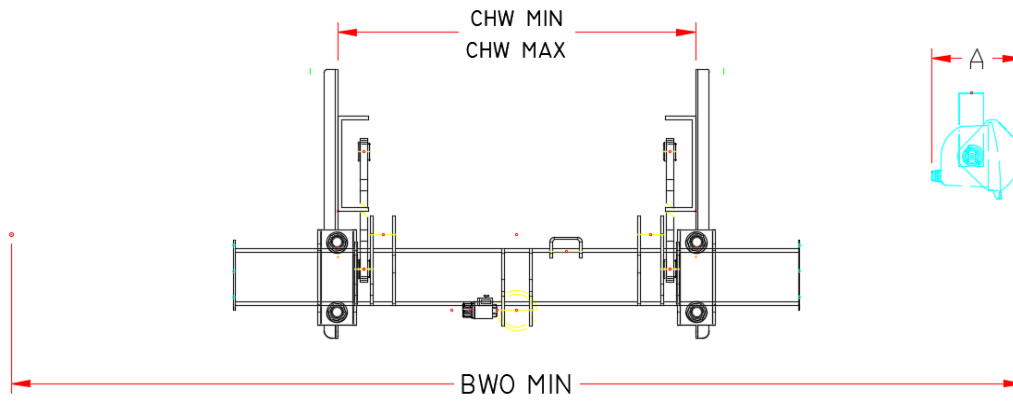

Figure 6.6



Dimensions table	
	mm
A	190
CHW MIN	750
CHW MAX	1060
BWO MIN	1980

- The tail lift is equipped with bolt-on mounting plates, adjustable in width for chassis width $750\text{mm} < W < 1060\text{mm}$. The mounting plates don't require any welding. [Figure 6.6]
- Refer to Figure 6.4 for the min. body width *BWO MIN*. required for installation with premounted pump unit.

NOTICE

- If you decide to remove the mounting bar and change the mounting height *MFT* of the tail lift, ensure to stay within the applicable ranges for the installation parameters *VFH*, *MFT* and *MTG*.
- Consult the national DHOLLANDIA distributor for confirmation of max. and min. mounting dimensions and obtain a chassis cut-out drawing for the new mounting height *MFT*.
- Mounting height *MFT* is measured from the top of the vehicle bed to top of the main frame tube. Use Figure 6.5 when determining mounting height *MFT*, make sure the height of the RUPD complies with regulations.

7 FLOOR EXTENSION PLATE AND CHASSIS CUT

Before Installation, verify the vehicle rear sill will support the required loads.

Remove all objects that are mounted in the overhang / mounting space required by the tail lift (ICC, spare tire carrier, pallet racks, tool boxes, walk ramps etc...).

The installation can be a STANDARD MOUNT [see Figure 7.1] whereby the bed extension is added behind the rear sill of the vehicle body. Or it can be a FLUSH MOUNT [Contact DHOLLANDIA for guidance], whereby the bed extension is integrated into the vehicle floor.

For standard mounts, remove dock bumpers, steps, or any protrusions that would prevent the deck extension from being mounted flush against the rear door sill.

Follow the chassis cut-out dimensions [Figure 7.2]. Trim the chassis beams, long sills, rear sill to the indicated dimensions.

It is possible to mount the lift at a higher mounting height MPG (e.g. to increase the ground clearance); or at a lower mounting height (e.g. to fit within a shorter mounting space). Ask DHOLLANDIA to confirm the required chassis cut-out dimensions, as these might change in relation to the new fitting height MPG.

Figure 7.1

STANDARD MOUNT

Dimensions table	
	mm
A	400
B	305
C MAX	152
D	317

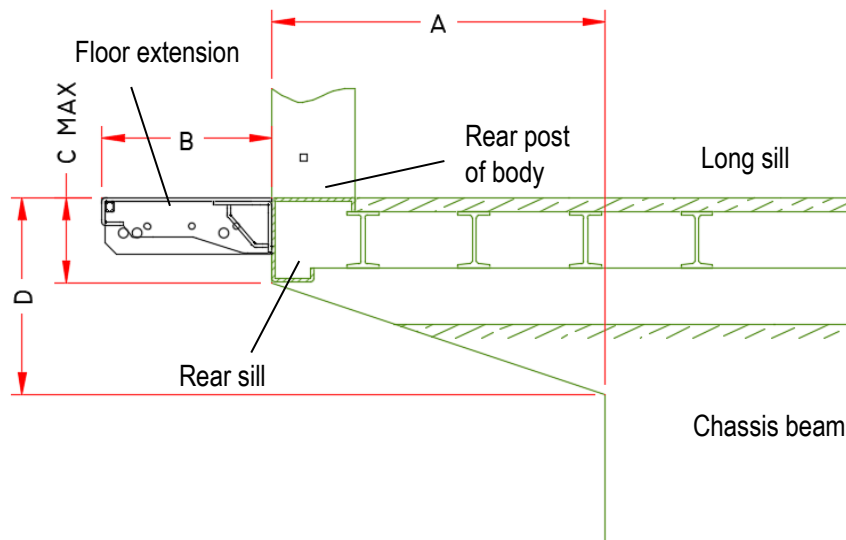
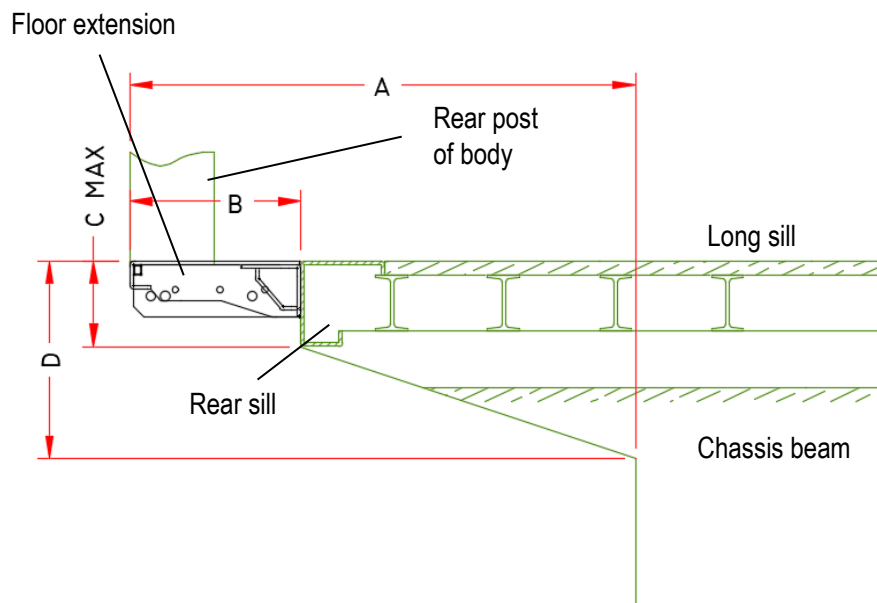

Figure 7.2

FLUSH MOUNT

Dimensions table	
	mm
A	400
B	305
C MAX	152
D	317



NOTICE

Where chassis beams, long sills, the rear sill and other steel chassis or body components have been cut, grinded, drilled, etc..., the installer should apply adequate anti-corrosive coating to protect the vehicle and body against corrosion. Check, and make sure you comply with the instructions of the OEM vehicle manufacturer.

8 MOUNTING OF THE EXTENSION PLATE

- The extension plate is supplied in galvanized finish and is intended to be bolted to the rear sill of the body. It is allowed to weld the extension to the rear sill, in addition to bolting, if desired.
- There are 2 models [see drawing in appendix]:
 1. Floor extension 2430mm wide (incl. side steps) for 2145mm platform width
 2. Floor extension 2590mm wide (incl. side steps) for 2300mm platform width
- Measure and mark the centreline of the body and sill.
- Measure and mark the centreline of the extension plate.
- Before drilling, verify the actual holes in the extension plate supplied with the drawing on right [Figure 8.1].
- Measure, mark and drill the 13 holes dia. 14.3mm required for mounting the extension, then coat the holes to protect against corrosion.
- Position the floor extension up to the rear sill using a fork lift or hoists.

Figure 8.1

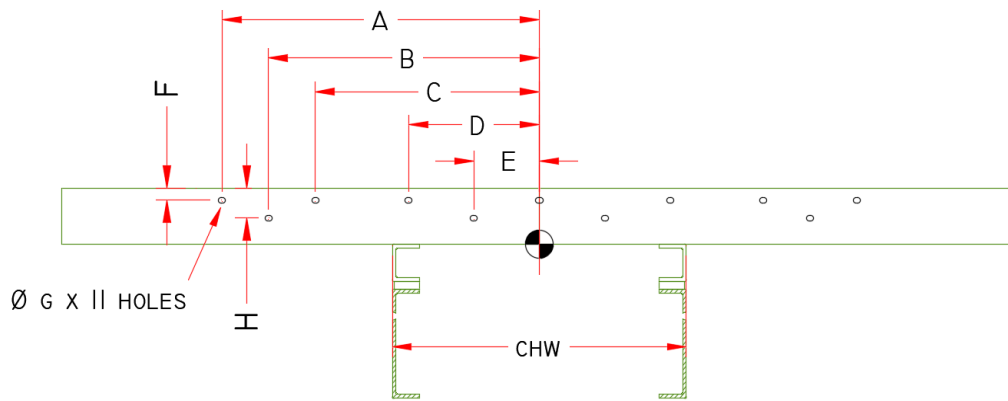

Dimensions table	
	mm
A	860
B	735
C	610
D	355
E	180
F	38
G	14
H	80

Figure 8.2

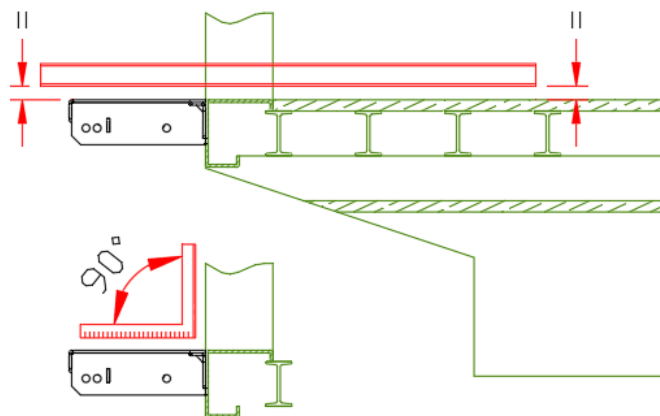

⚠ WARNING

- The extension plate is very heavy! When falling on a person, it can cause serious personal injury or death.
- Therefore, handle the plate with care. Use lifting aids such as a forklift, gantry crane, hoists etc... to secure the plate, and prevent it from falling.
- Align the centreline of the extension plate to the centreline of the rear sill. Make sure it is level with vehicle floor [Figure 8.2]. If not level, vary the mating surfaces between the extension plate and rear sill, remove any obstructions, or adjust as needed.
- Bolt the extension plate to the rear sill, using 11 bolts M14 and locking nuts supplied with the tail lift [Figure 8.3]:

- Mount all bolts and locking nuts and fasten them hand-tight.
- Ensure the extension plate is level with the vehicle floor [Figure 8.2]; and flush with the top surface of the rear sill.
- Then tighten the bolts to the required torque. Work from the centre outward.

Figure 8.3

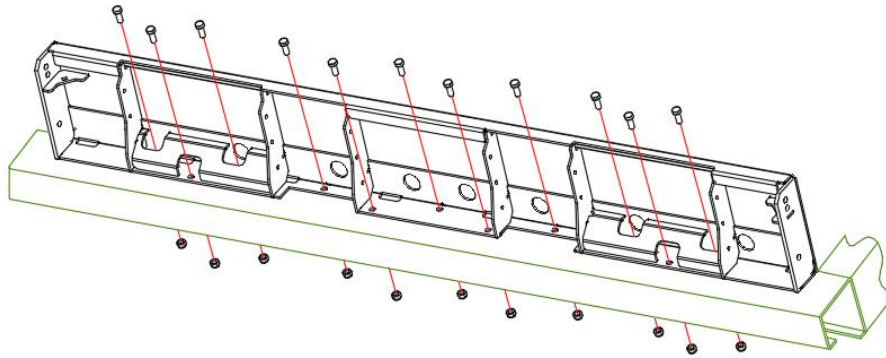

Total extension plate	
11x M14x1.5 (10.9)	185 Nm

The extension plate may also be welded to the rear sill [Figure 8.4].

- Tack weld the extension plate, working from the centre outward, making leveling adjustments as you proceed.
- Finish with 7 welds of 5mm, 102mm long on the top and bottom.
- DO NOT weld in the areas left and right, where the steps and dock bumpers will be bolted on.

Figure 8.4

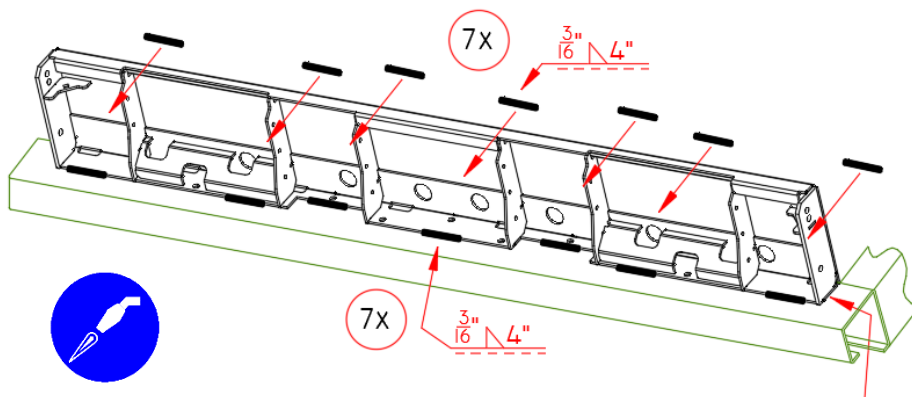

DO NOT weld at the sides

CAUTION



- Before welding, note that welding on galvanized parts releases hazardous fumes. Provide adequate ventilation, and wear an appropriate toxic fume rated welding respirator.
- It is strongly recommended to first grind off the galvanizing in areas where welding is to be done.

9 MOUNTING OF THE LIFT FRAME (PREMOUNTED PLATFORM)

- Bring the shipping pallet with the tail lift to the rear of the vehicle.

NOTICE

When manipulating the tail lift with a forklift or hoists etc... be very careful, and make sure you don't damage the cylinder lock valves, hydraulic pipes, and other easily breakable components.

- Before raising the platform and lift frame into position, be sure to turn the platform tilt adjustment bolts all the way IN to the stops. [Figure 9.1]

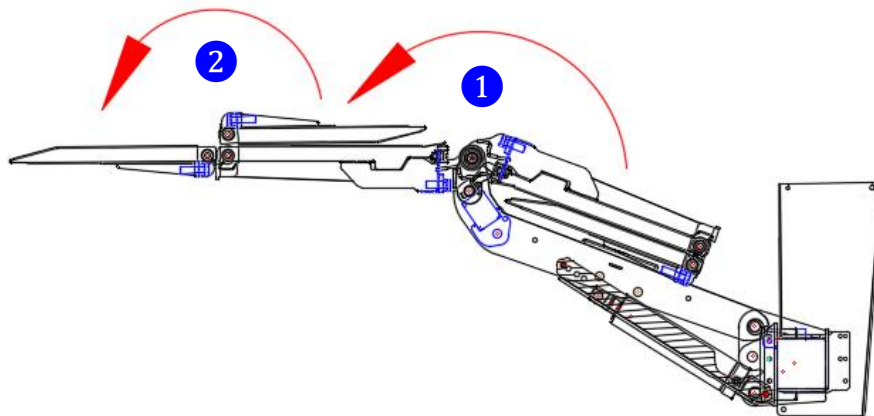

Figure 9.1



- Manually unfold the foldable platform with its 2 platform sections. Then unfold the flip-over point. [Figure 9.2]

Figure 9.2



WARNING

- The platform sections are very heavy! In the current mounting position, the platform open-assist springs are not helpful. When falling on a person, these platform sections can cause serious personal injury or death.
- Therefore, handle the platform with care. Use lifting aids such as a forklift, gantry crane, hoists and clamps etc... to assist you through the unfolding movement

- Mount the mounting plates on the lift frame and tighten the bolts by hand. [Figure 9.3]
- Each mounting plate is bolted to the lift frame by means of [Figure 9.3]:
 1. Fit the mounting plate over the frame [1]
 2. Fit the clamps over the designated screw threads of the mounting plates. [2]
 3. Place the self-locking nuts M24 over the screw threads of the mounting plates and hand tighten them. [3]

Figure 9.3

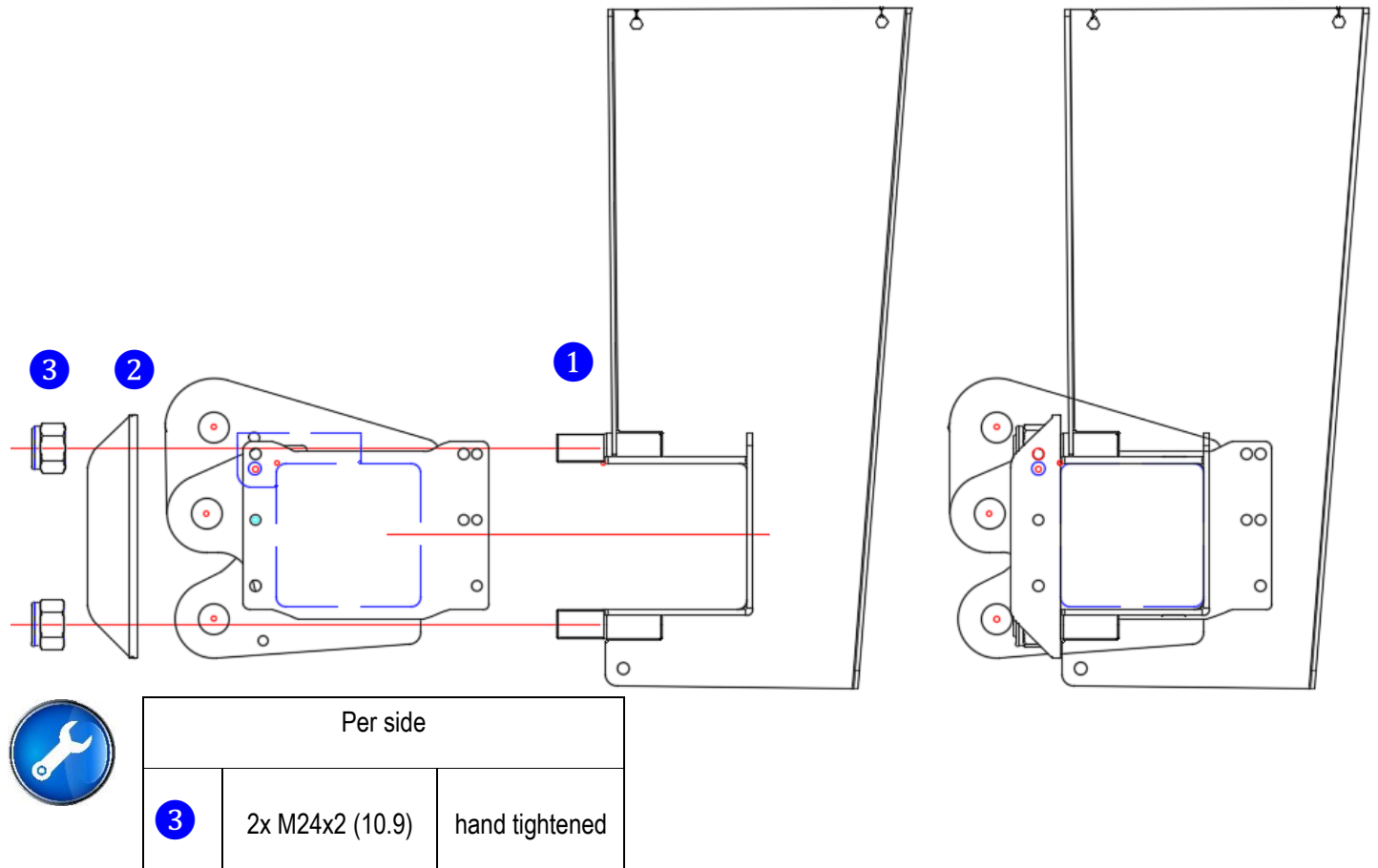

See also

- Slide the mounting plates outward as much as possible, to obtain max. clearance when raising the lift frame over the vehicle chassis.
- Clamp 2 lengths of tube or angle brackets, min. 76mm² x 4mm) wall thickness or equivalent, to the extension plate with min. 500mm overhang. These brackets will help align the platform with the extension plate. [Figure 9.4].
- Install a min. 136kg counter weight on the channels to prevent them from moving during installation. Or tack-weld the brackets temporarily to the rear sill and floor of the vehicle.

Figure 9.4

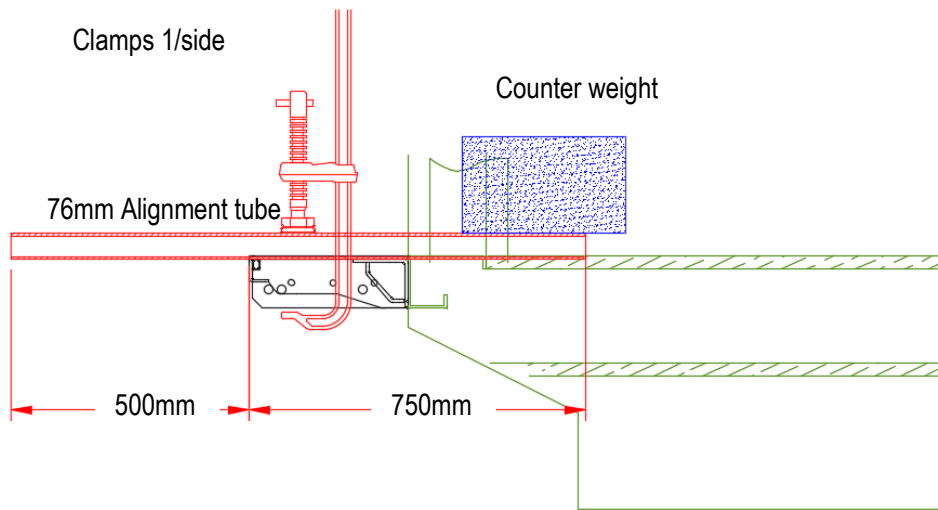

- Affix hoists at the inboard platform edge, left and right. Place C-clamps on each side of the platform to prevent the hoist chain from slipping off the platform. [Figure 9.5]
- DO NOT affix hoists to the flip-over point, as this section doesn't provide a stable hold of the platform and lift frame, and damage to the point might occur. [Figure 9.5]
- Hoist the platform and attached lift frame and place a hydraulic jack under the lift frame. [Figure 9.5]

Figure 9.5

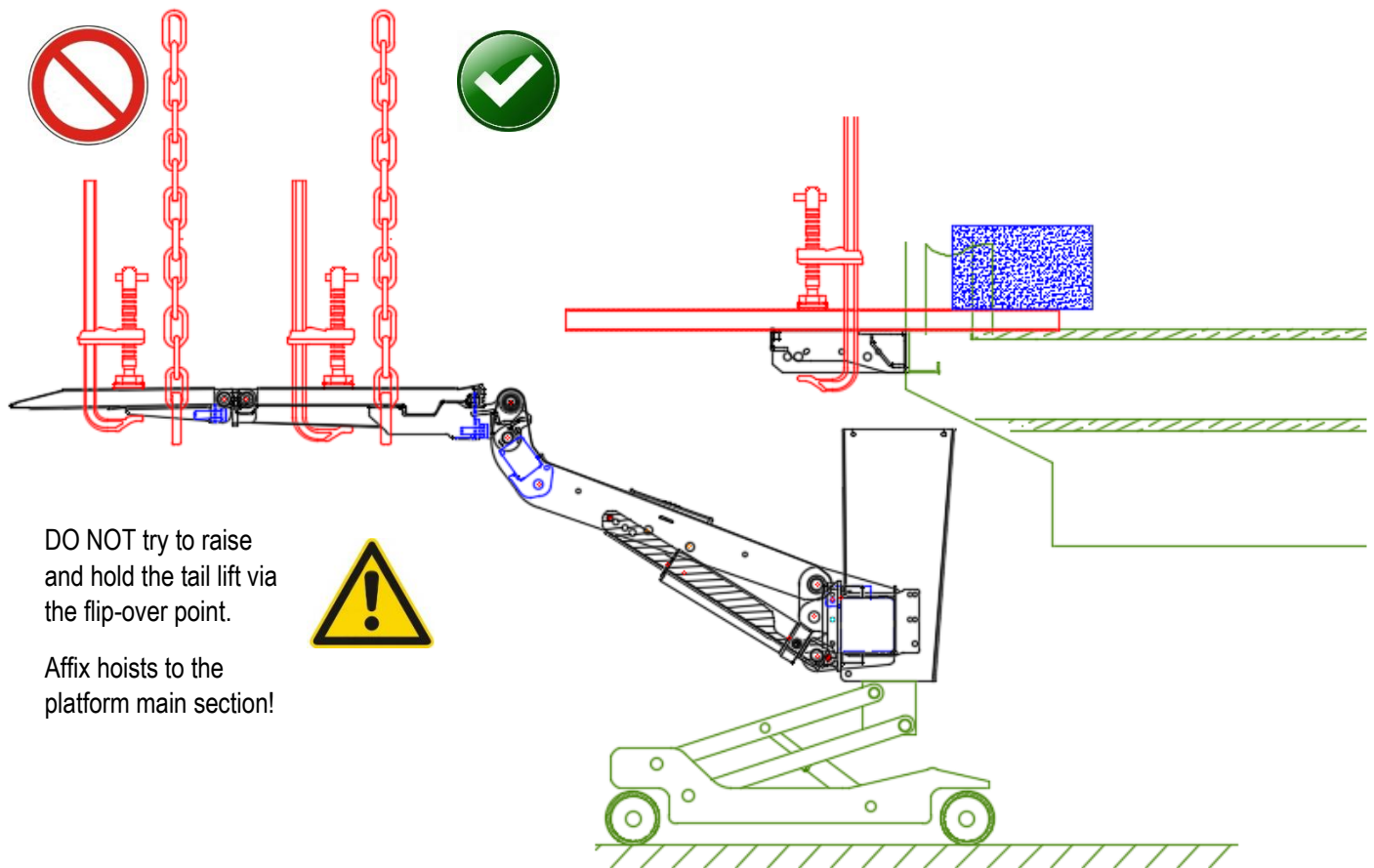

DO NOT try to raise and hold the tail lift via the flip-over point.

Affix hoists to the platform main section!

WARNING

- The platform and attached lift frame are very heavy! When falling on a person, they can cause serious personal injury or death.
- Therefore, handle the platform and attached lift frame with great care. Use hoists and a gantry crane to raise the platform and attached lift frame in their correct mounting position.
- Place C-clamps on each side of the platform to prevent the hoist chain from slipping off the platform.

- Hoist the platform up to extension plate and 76mm alignment tubes. Simultaneously jack the lift frame up to the correct mounting height *MFT*. [Figure 9.6]
- When jacking up the lift frame, push from the centreline of the lift frame. DO NOT apply force at either end of the lift frame to change or correct the mounting height at one side only.
- Ensure that the platform is centred in the centreline of the vehicle, and that it is flush and parallel with the extension plate.
- Secure the correct platform position by clamping the platform main section to the 76mm mounting tubes. [Figure 9.6]

Figure 9.6

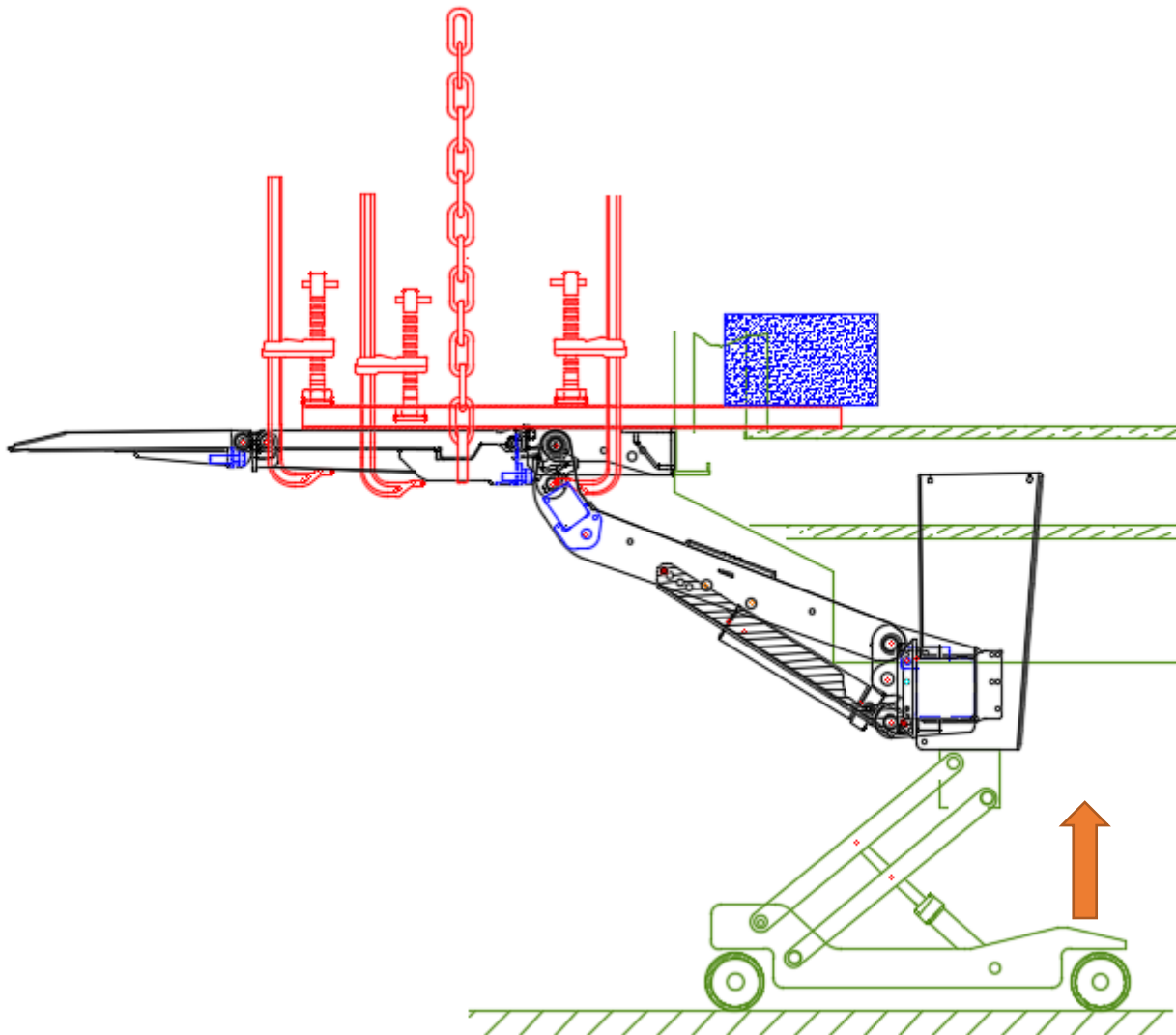

- If required, tilt the lift frame relative to the vehicle chassis, to ensure that the top surface of the lift frame is parallel to the vehicle floor. A torpedo level is commonly used to ensure the alignment of the lift frame and vehicle floor. If convenient, the piston-rod ends of the lift cylinders may be disconnected so that the lift arms and lift frame can move freely. [Figure 9.7]

Figure 9.7

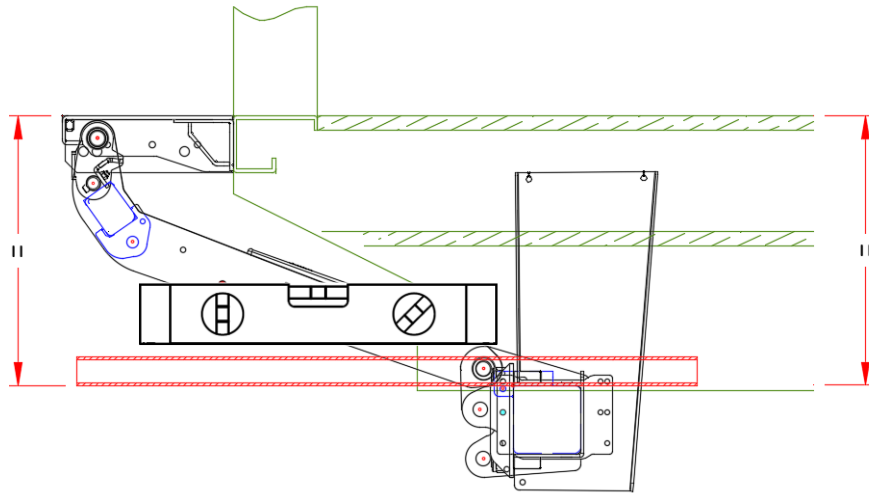

NOTICE

Ensure the platform and lift frame are positioned in conformance with the mounting instructions and dimensions indicated in the installation drawing and manual, before drilling or welding the mounting plates to the chassis.

It is not allowed to reduce the width of the mounting plates without prior written authorization from DHOLLANDIA.

10 FIXATION OF THE BOLT-ON MOUNTING PLATES

- The mounting plates are designed as a bolt-on system, both where they mount to the lift frame, and where they mount to the vehicle chassis.
- If you intend to weld, beware of precautions below:

NOTICE



WARNING

- The tail lift might be equipped with thermoplastic hydraulic pipes, that can be easily damaged by welding. Damage to a pipe can lead to sudden pressure loss, and accidental drop of the platform.
- Welding sparks and slag penetrating hydraulic pipes under pressure, could cause a flaming flash, and serious personal injury to the welder and any bystanders.
- To avoid risk of serious personal injury, ALWAYS use adequate coverage (e.g. by a leather welding blanket) to shield the thermoplastic pipes whenever welding is done on or near the tail lift.

CAUTION



- Before welding, note that welding on galvanized parts releases hazardous fumes. Provide adequate ventilation, and wear an appropriate toxic fume rated welding respirator
- It is strongly recommended to first grind off the galvanizing in areas where welding is to be done.

NOTICE

- Some OEM vehicle manufacturers prohibit welding on the vehicle chassis.
- Verify the body builder guidelines issued by the OEM vehicle manufacturer, and make sure you comply.

Figure 10.1

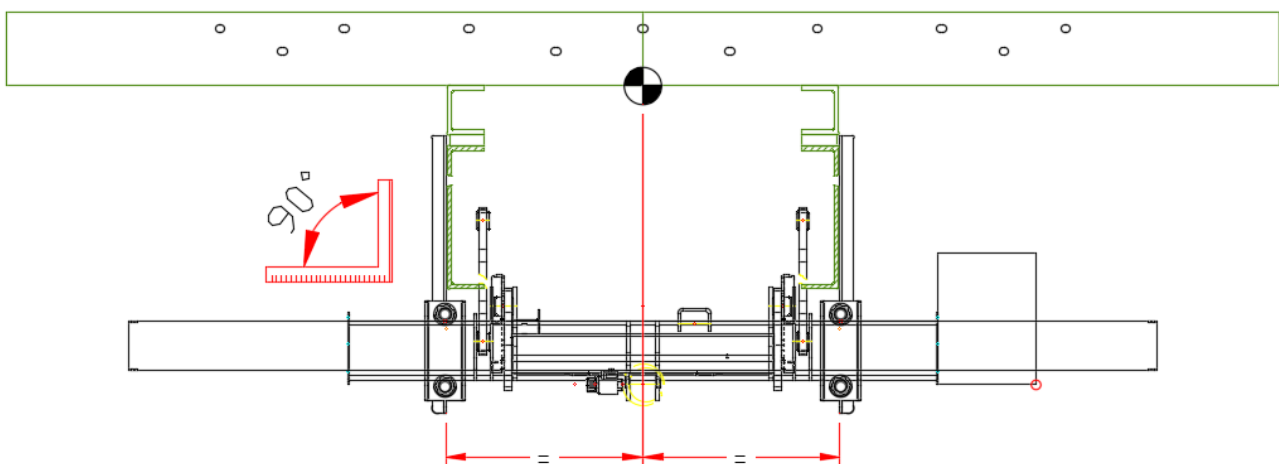

- See section 9 on page 21 for initial positioning of the mounting plates.

- Slide the mounting plates sideways until they are perfectly aligned with the chassis rails. [Figure 10.1]
 - Straighten the mounting plates, and make sure they stand perpendicular to the lift frame. Ensure the lift frame is correctly centred under the vehicle chassis and body. [Figure 10.1]
- The mounting plates **MUST** be bolted to the lift frame according to the instructions in Figure 9.6. Tighten the bolts and nuts with the prescribed torque.



Figure 10.2

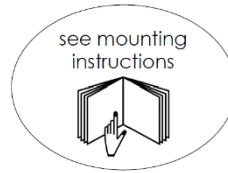
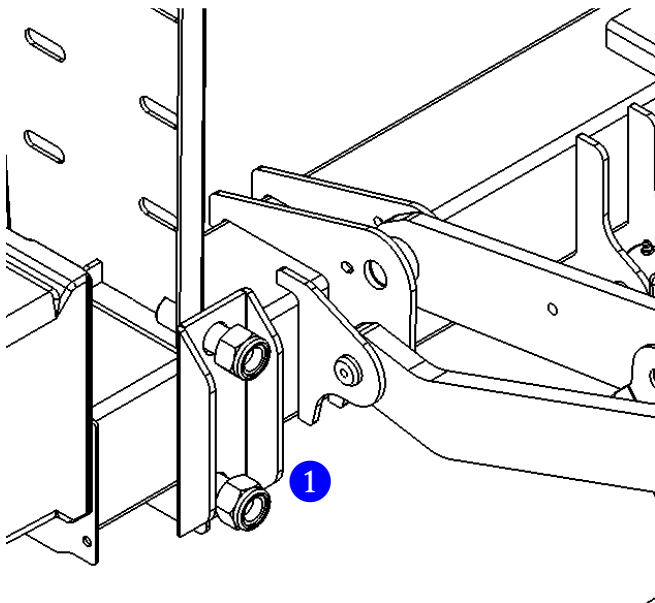

Per side			
1	2x M24x2 (10.9)	hand tightened	185Nm



The mounting plates **MUST** be bolted to the vehicle chassis, the bolts and nuts tightened with the required torque, according to the instructions below and on right side.

- Pay special attention to the type, minimum quantity, minimum size and strength, position and prescribed torque. [Figure 10.3]

WARNING

- Incorrect installation of the mounting plates and bolts can lead to accidental fall of the tail lift off the vehicle chassis.
- A fall of the tail lift off the chassis can damage the tail lift and / or vehicle chassis and can cause serious bodily injury or death to the operator and any bystanders.
- Therefore, it is essential that the mounting plates are installed following the instructions of this manual.

- The mounting plates are bolted to the vehicle chassis with min. 6 bolts M14 per side, supplied with the lift, spread over the widest possible surface to maximize the strength of the bolted connection. Fasten the 6 bolts M14 per side with the required torque. [Figure 10.3]

Figure 10.3

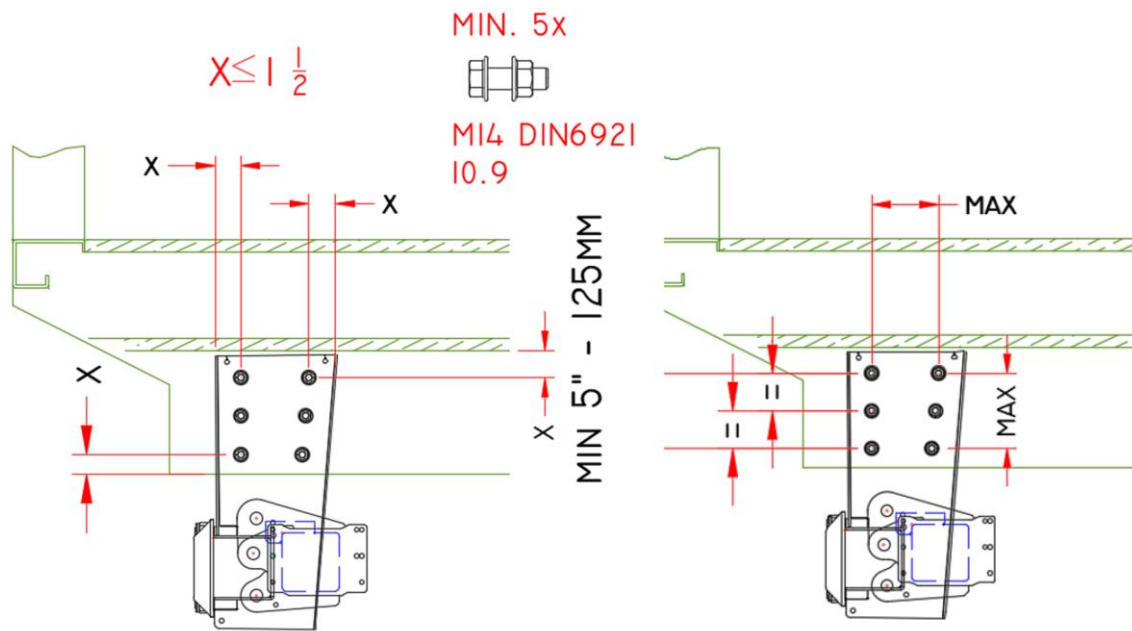

Per side	
Min. 6x M14x1.5 (10.9)	185 Nm

Figure 10.4



Per side	
Extra 2x M14 (10.9)	185 Nm

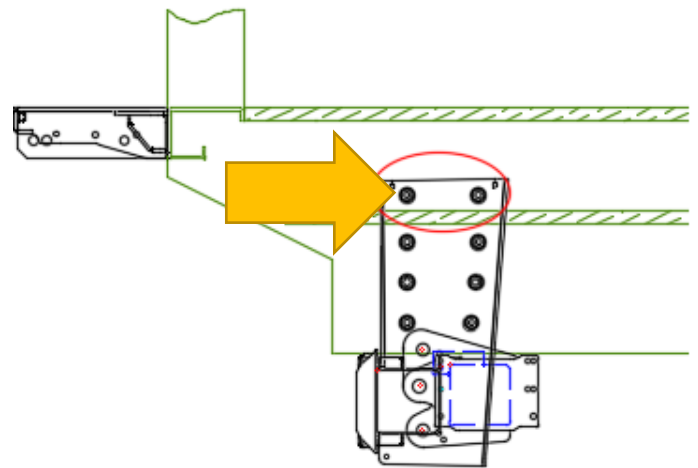

- Check if the long sills, the body cross members and floor are securely attached to the chassis and will form one solid construction once weight will be applied on the platform. If not, attach the mounting plates of the tail lift to the long sills on top of the chassis by means of 2 additional bolts M14 per side, or equivalent. [Figure 10.4]. Fasten these bolts with the required torque.

- Alternatively, the mounting plates may be welded to the chassis rails instead of bolted. When doing so, observe the precautions regarding welding on galvanized steel on page 22.
- Make min. 6 pcs. 10mm welds, min. 102mm long, evenly spread around the periphery of the mounting plates (per plate). [Figure 10.5]
- When there is an overlap between the mounting plates and the long sills, make min. 2 pcs. 10mm welds, min. 102mm long, at the top of the mounting plates (per plate). [Figure 10.5]
- If there is no overlap, add a connection plate to extend the height of the mounting plate, overlap the long sills, and make min. 2 pcs. 10mm welds, min. 102mm long, at the top of the mounting plates (per plate). Apply equivalent welds to join the mounting plate with the connection plate. [Figure 10.6]

Figure 10.5

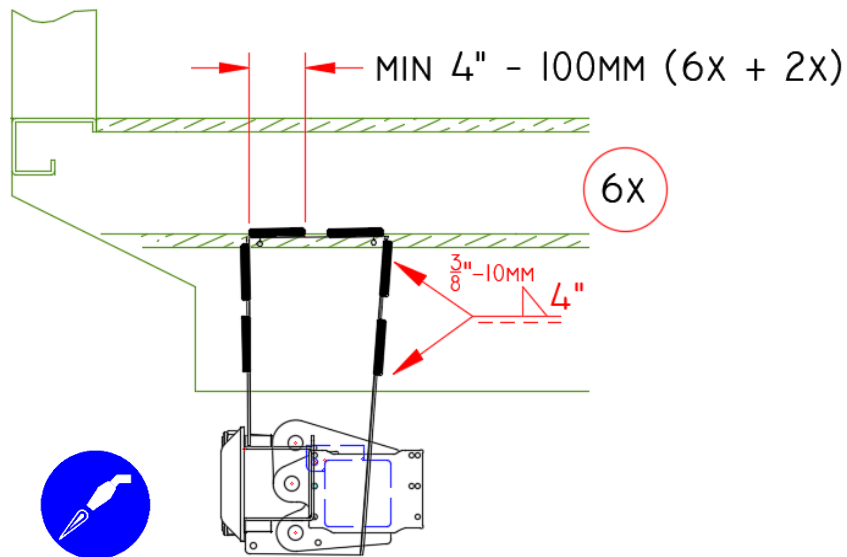
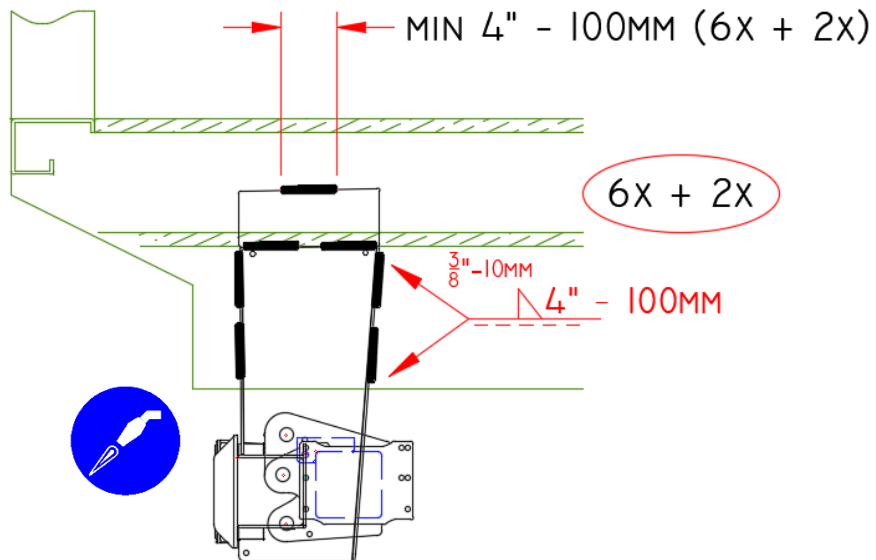

Figure 10.6



⚠ WARNING

- During installation, the bolts and nuts should be fastened to the proper torque, shown in these installation instructions.
- If you use mounting bolts not supplied by DHOLLANDIA, make sure the total strength is at least equivalent as per this manual.
- Check and retighten the bolts after static and dynamic load tests performed at the end of the installation process.

11 INSTALLATION OF CONTROL SWITCH

11.1 MOUNTING OF THE CONTROL SWITCH

- Mount the toggle switch in a position that allows the operator to **work from a safe standing area at the side of the tail lift, outside reach of the platform and other moving parts of the lift.**
- Mount it in a location that is accessible from the ground and the vehicle floor level.

NOTICE

In order to avoid water ingress and electrical malfunction, NEVER mount the toggle switch facing upward. [Figure 11.]

- Measure the holes on the control unit itself or use the template [Figure 11.1] to drill the screw holes, and the passage for the electrical cable.
- Use 4.3mm self-tapping screws to mount the control switch.
- Route the electrical cable to the pump unit. Position, fasten and protect it in such a way that it cannot be damaged by the moving parts of the tail lift or other vehicle components.

Figure 11.1

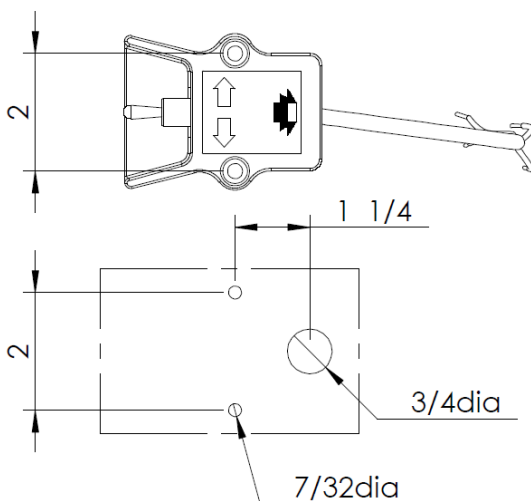
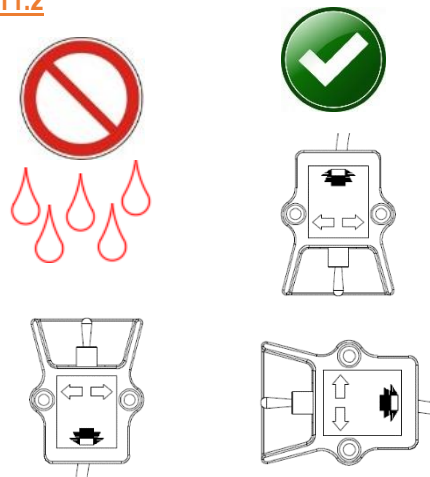
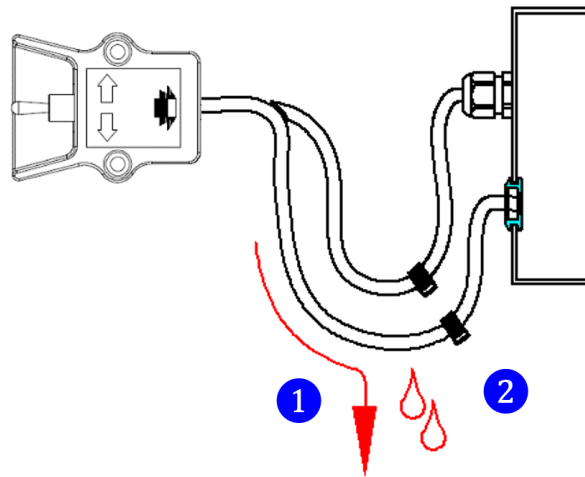

Figure 11.2



- Feed the electrical cable through the rubber grommet at the rear of the pump unit. **Check and make sure the rubber grommet properly seals and protects the inside of the pump unit, after passing the cable.**
- Prevent ingress of water into the pump unit and control boxes if applicable [Figure 11.2 - Figure 11.3]:
 - Route and secure cables downward, forming a “drip loop” as they exit the pump unit.
 - Wrap a zip-tie around the cable before it enters the pump unit or control box. This will help to interrupt the flow of water into the enclosure.
- Connect the wires of the cable to the connection points in the pump unit, as per wiring diagrams attached.
- Coil in the excess cable inside the pump unit. Fix and immobilize it with cable ties to the hydraulic return pipe of the valve block.

Figure 11.3



- The main wiring diagrams are included in the pages hereafter, and in the appendix.
- The wiring logic for the DH-RP.10 with power down function (ref. OAH025.01) is called DAD4 [Figure 11.4], and uses the following abbreviations:

R = starter solenoid for the DC motor

S4 = 4/2 valve on the rear side of the pump unit

D = self-locking valve on the lift cylinders

SA = single acting lock valve

Figure 11.4

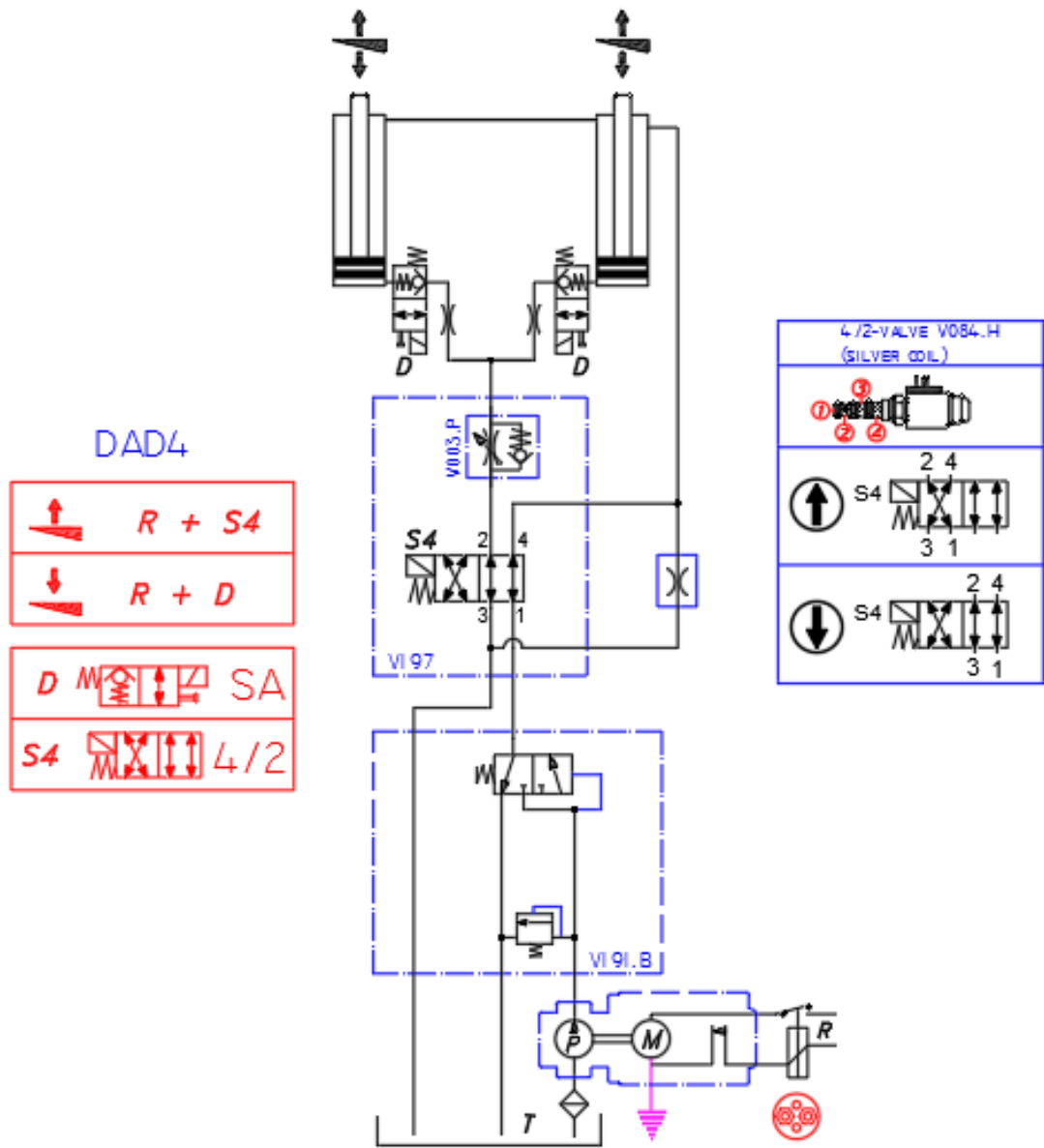
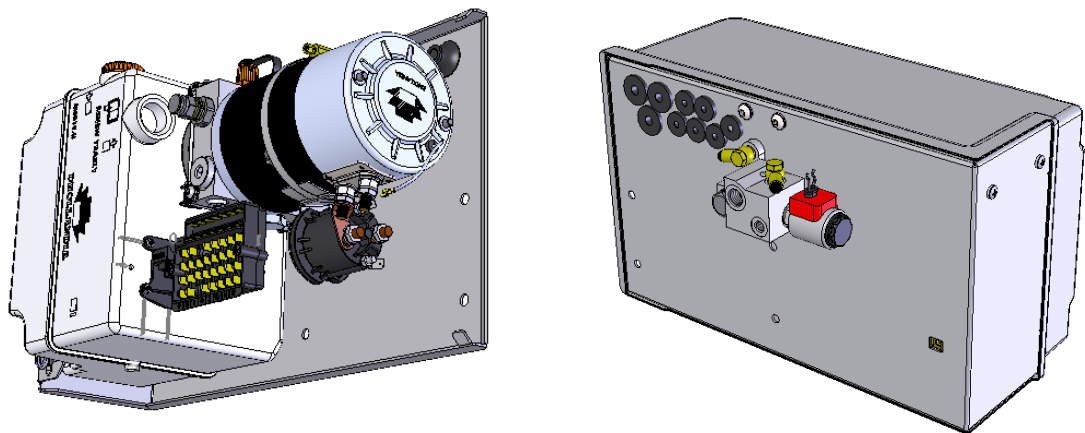

Figure 11.5



11.2 CONNECTION BLOCK TERMINOLOGY

- The connection block distributes voltage signals to the corresponding pins for each desired function. [Figure 11.6]

Figure 11.6

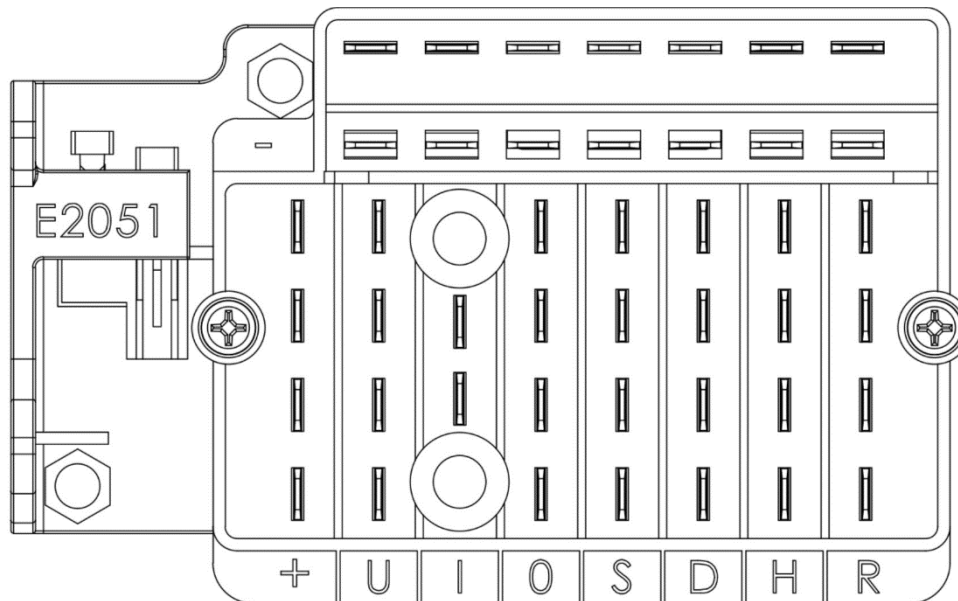

Horizontal pins are ground connections

+ - Positive connection for extra controls

R - Starter solenoid on motor

H – Control valve (lift) at the back of the power pack

D – Electrical self-locking valves (Lower) on the lift cylinders

S – Control valve (Close/Tilt up) in the power pack

O – Electrical self-locking valves (Open/Tilt/Down) on the tilt cylinders

I – Control valve (Slide In) in the power pack

U – Control valve (Slide In) in the power pack

11.3 GRAVITY DOWN WIRING FOR THE CONTROL SWITCH

- The control switch and relay MUST be correctly wired to the connection block for proper operation. [Figure 11.7]

Figure 11.7

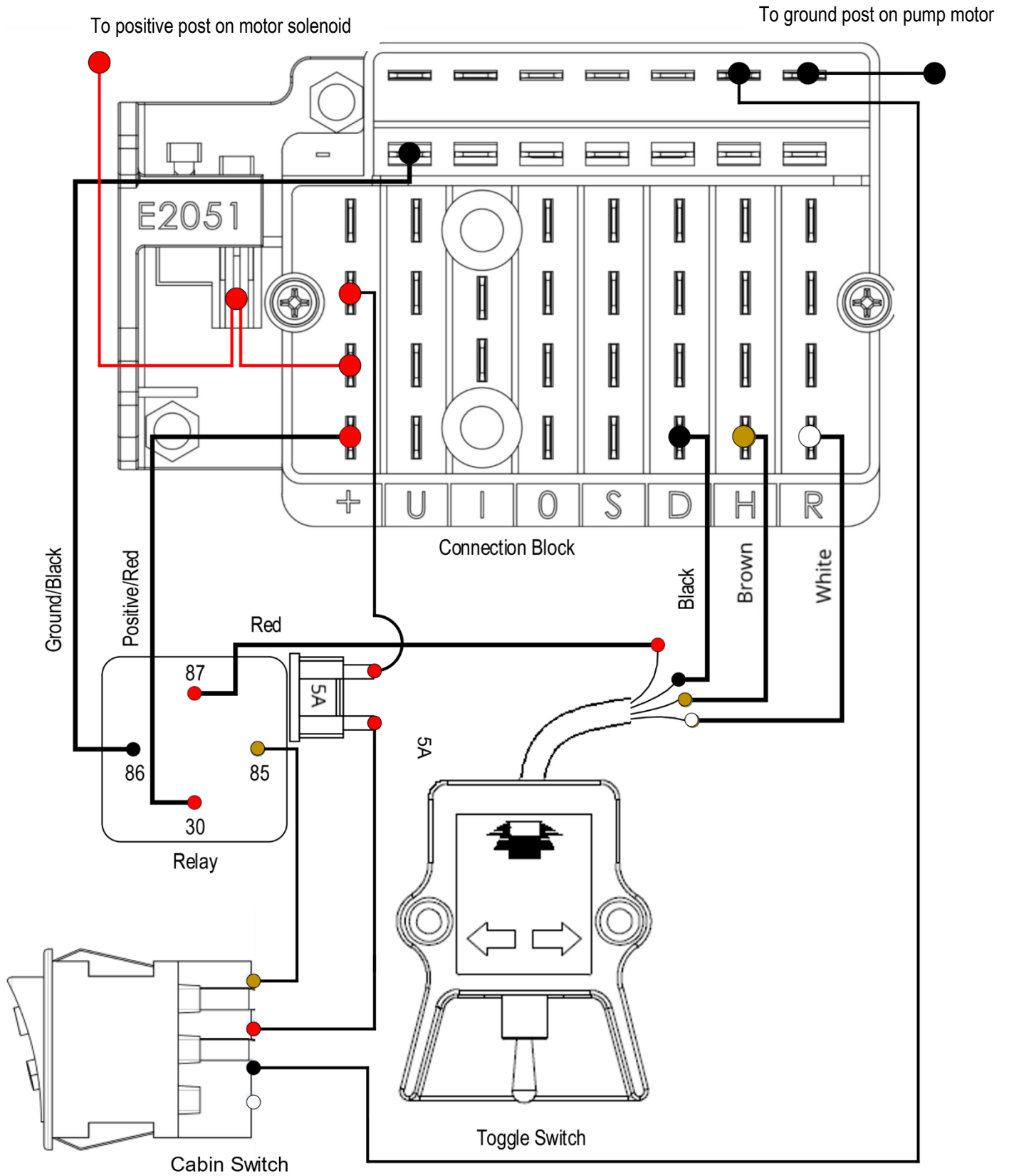

- For option OAE510.15, see Figure 11.8, below:

Figure 11.8

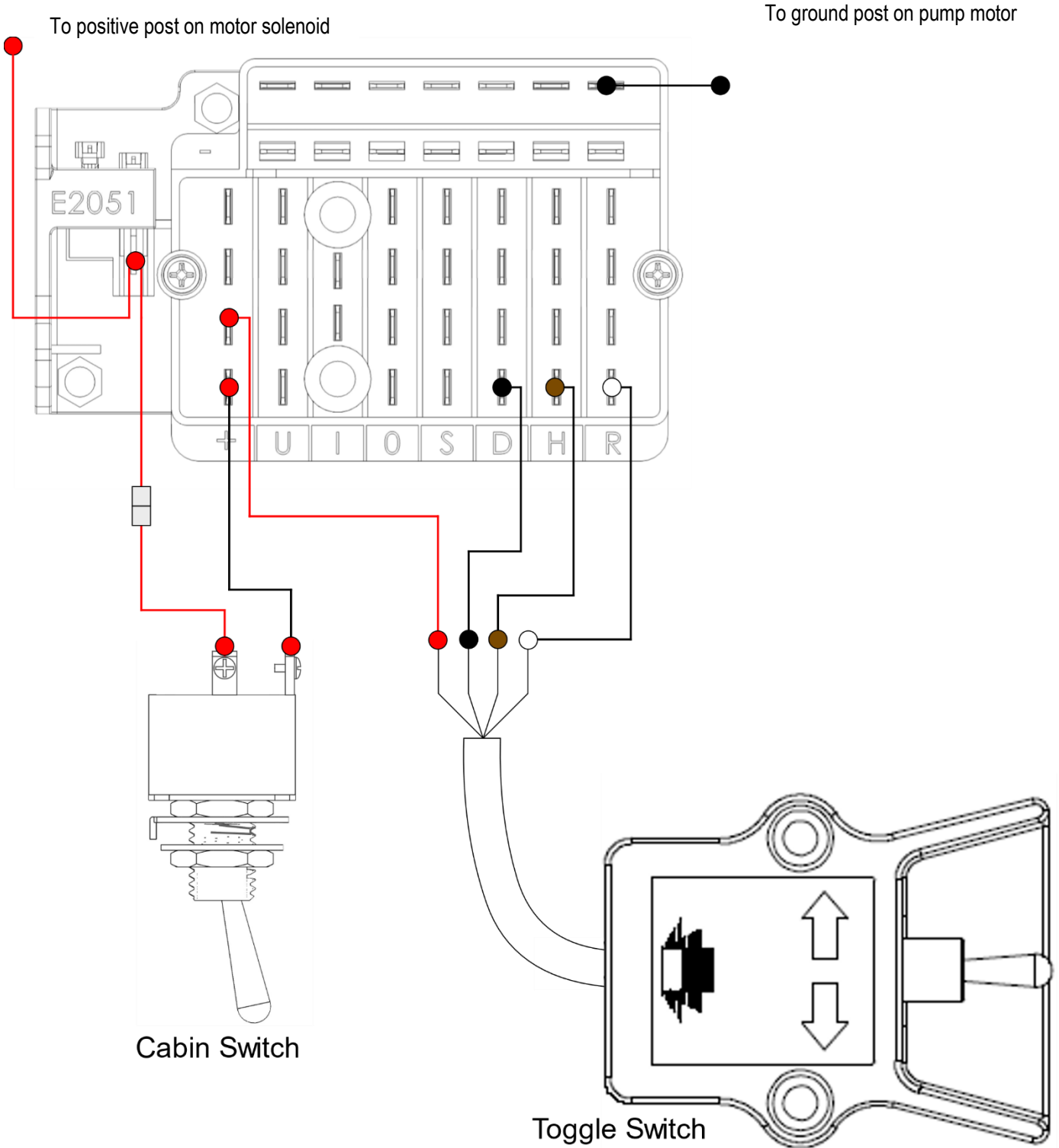

11.4 POWER DOWN WIRING FOR THE CONTROL SWITCH

- The control switch and relay MUST be correctly wired to the connection block for proper operation. [Figure 11.9]

Figure 11.9

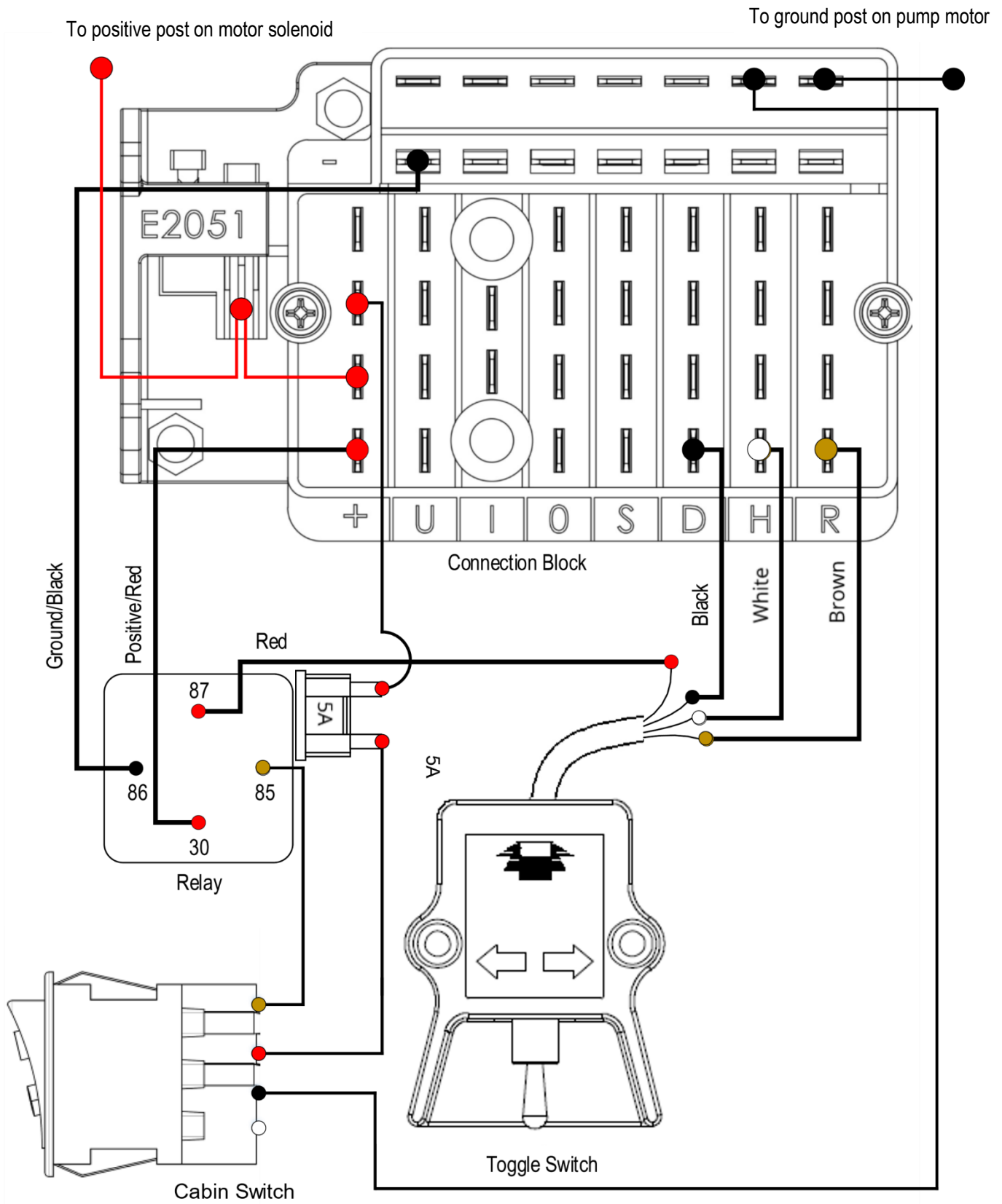

- For option OAE510.15, see Figure 11.10, below:

Figure 11.10

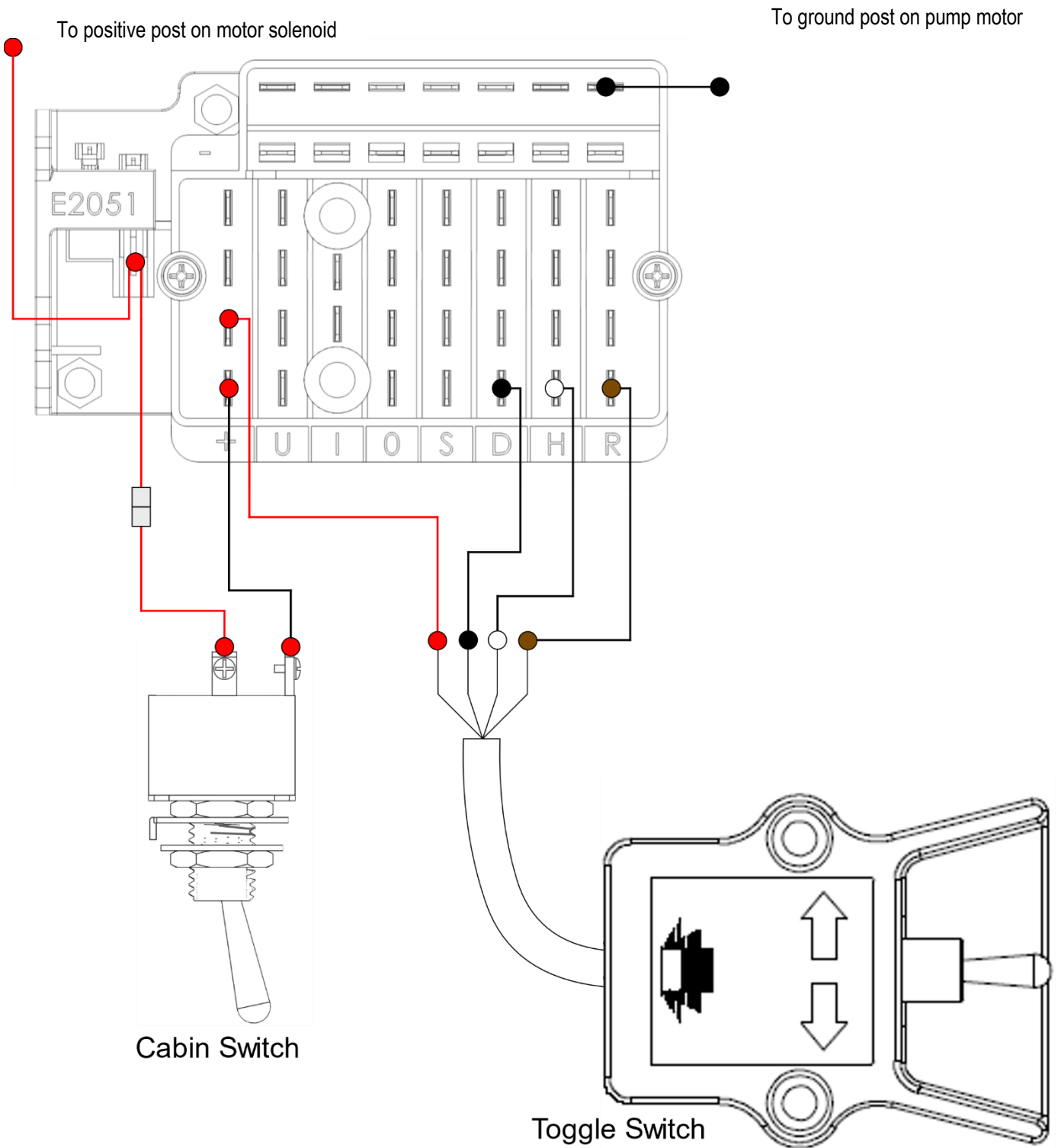

12 CONNECTION TO THE BATTERIES

- A general schematic of how to correctly connect the batteries to the tail lift is provided in Figure 12.1.

Figure 12.1

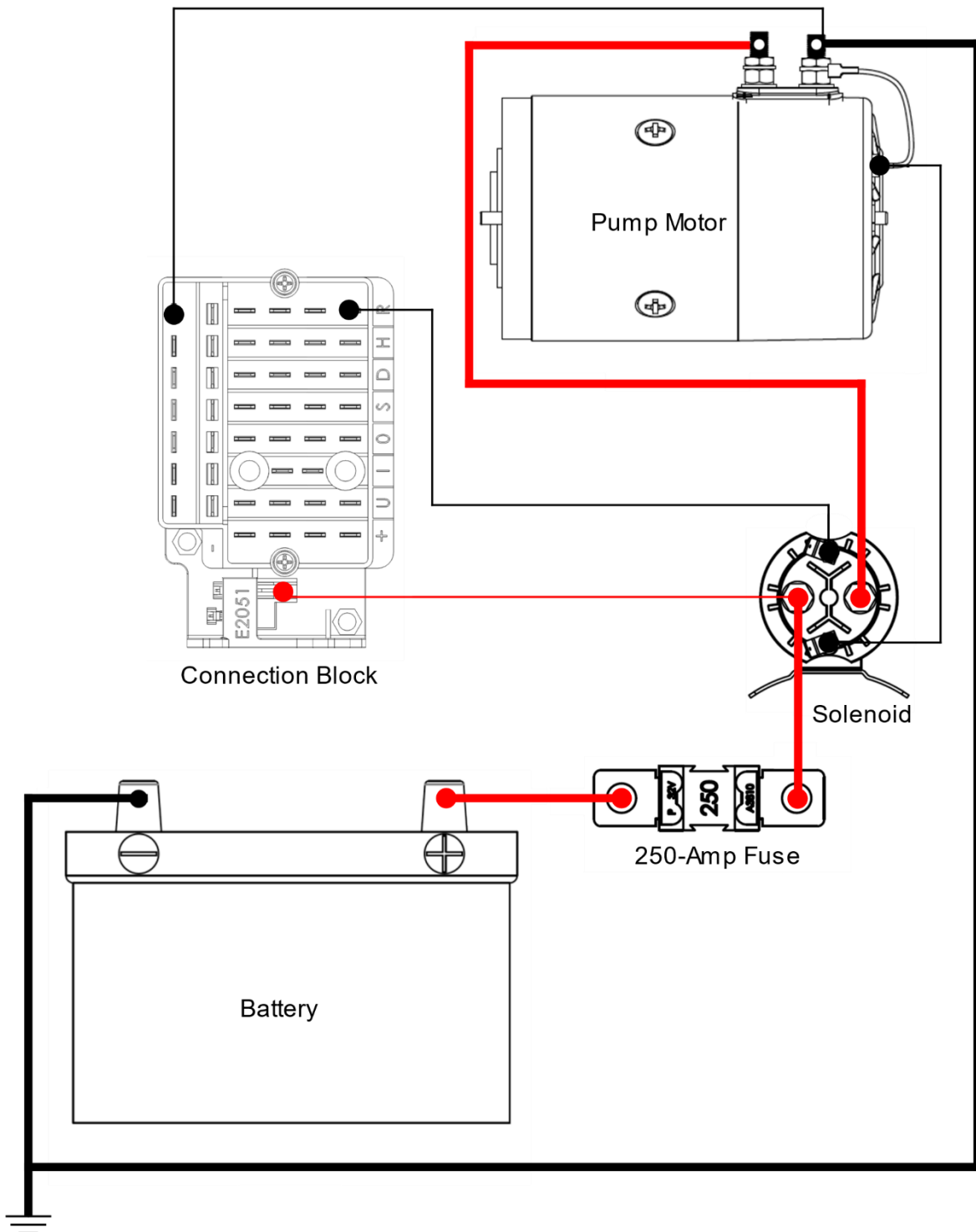



- Refer to the separate manual ELECTRICAL INSTALLATION N-A GENERAL 01 for more detailed information on the electrical installation, connection to the tail lift or vehicle batteries, installation of fuses or circuit breakers, and ground connections.



- If not supplied with the tail lift, these can be downloaded from the “DOWNLOAD” section on our website:
<http://www.dhollandia.com>
- Please confirm you have reviewed the most up-to-date version of this manual prior to continuing.
- If you want to operate the tail lift before the batteries are installed, use a temporary battery of min. equivalent power as the final battery, charged by a battery charger connected to a wall plug. [Figure 12.2]

Figure 12.2

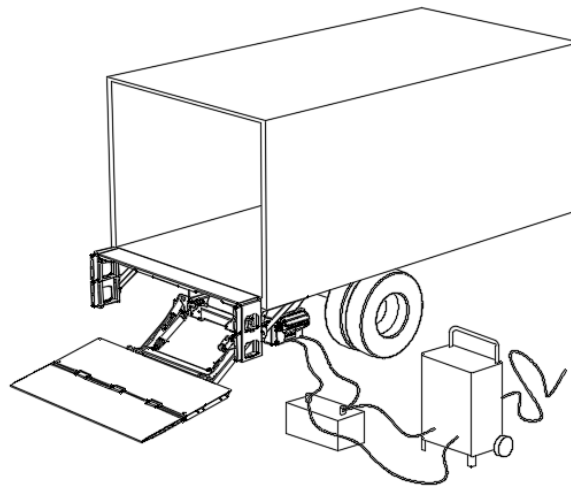

NOTICE

NEVER run a tail lift from a battery charger only. This can cause damage to the pump unit and electrical parts of the tail lift.

13 PUTTING THE TAIL LIFT INTO SERVICE

- Remove the mounting bar from between the lift arms and the lift frame (used to install lift at pre-defined mounting height *MFT*). [Figure 13.1]
- Switch on the main electrical power to the tail lift.
- Push the LIFT button to pressurize the hydraulic system. Stop when you hear the hydraulic pump turn in overpressure.

Figure 13.1

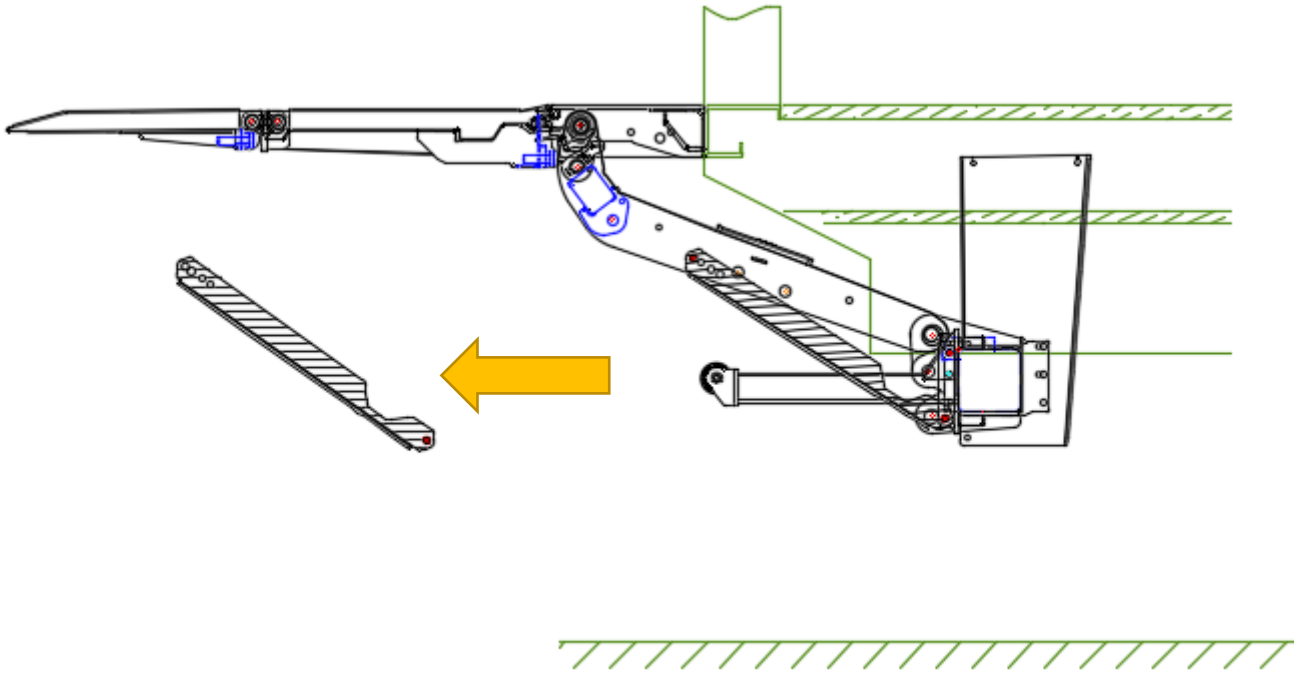

NOTICE

Check for visible leaks of hydraulic oil as the system is being pressurized. If there is leakage, correct the problem prior to continuing.



WARNING

- Improper use of the tail lift will put the operator at great risk of serious bodily injury and death. If in doubt how to use tail lift correctly, installer should consult the operation manual prior to continuing
- Air might be trapped in the hydraulic circuits, as long as the tail lift has not been bled. Air can cause the tail lift to make unexpected movements and can put the installer at great risk of serious bodily injury. The installer should remain vigilant and stay out of the range of motion of the platform and the moving parts of the tail lift as long as the hydraulic circuits have not been purged.

- Lower and remove the hydraulic mounting jack.
- Remove the C-clamps, chains, hoists and other supports that have been used during installation.
- Push the LOWER button to lower the platform to the ground.
- Test the LIFT and LOWER functions at least 5 times. Look for any interference between the tail lift and the vehicle. The tail lift should operate smoothly and quietly, at a fairly constant speed.
- Only the sound of the pump unit should be audible. In case of jerking movements or odd sounds, you should investigate and correct to avoid damage to the tail lift or potential hazards for the operators.
- Bleed all air from the hydraulic circuits. Preferably raise the rear end of the vehicle off the ground or raise the vehicle air suspension to its allowed maximum. LIFT the platform to vehicle floor level. [Figure 13.2]
- Then LOWER the platform fully to its deepest position at the ground, continue to press LOWER for 20 sec. LIFT the platform again, and repeat until no air bubbles run back to the oil reservoir. [Figure 13.2]

Figure 13.2

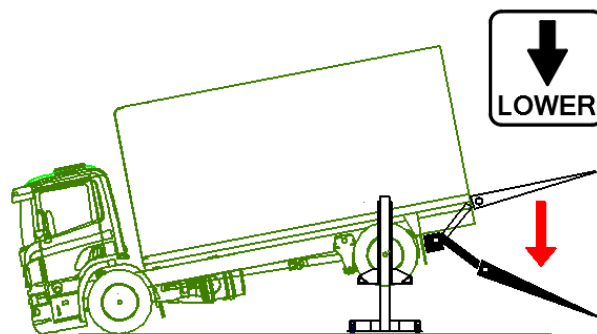

- The platform opener assembly is pre-installed at the factory. If removed, mount it back in its original position to avoid damaging the platform prior to operating the tail lift.

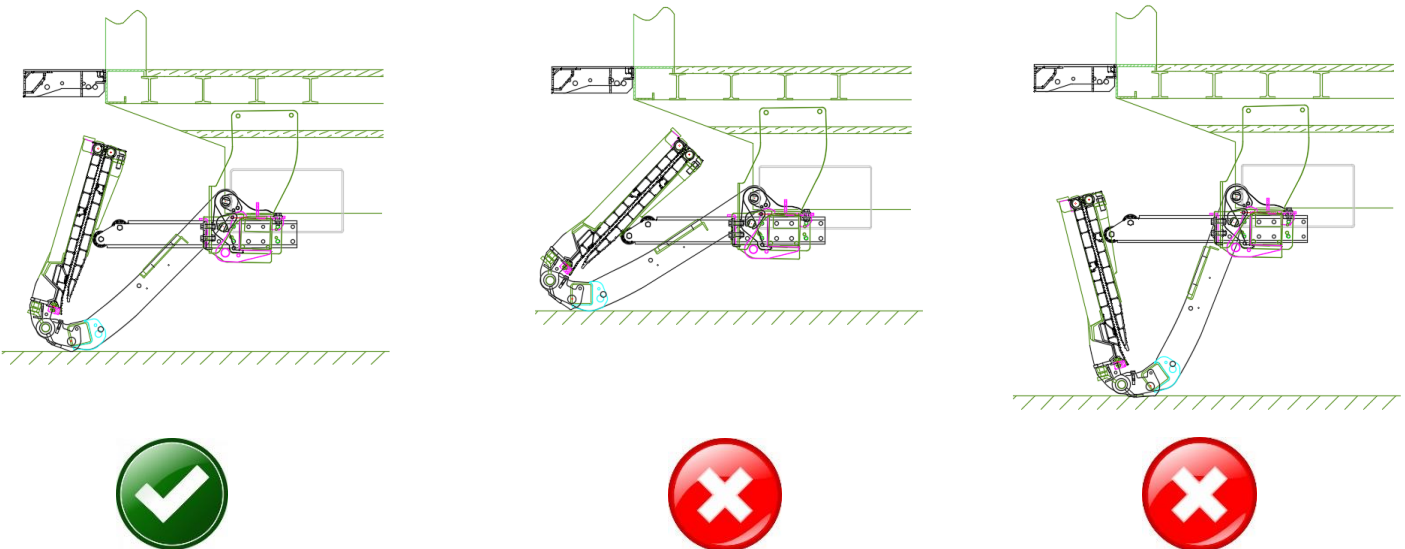

14 PLATFORM ORIENTATION

1. LIFT the platform to the floor height. Lay a straight edge lengthwise across the platform. Make sure the flip-over point and platform main section are even with each other. [Figure 14.1]
2. If needed, adjust the angle between the 2 platform sections by turning the 2 adjuster bolts at the underside of the platform main section. Loosen the counter nuts, then adjust bolt length, and retighten the counter nuts. [Figure 14.1]. **Make sure both sides are adjusted equally, so that all bolts will support the flip-over point (and its load) evenly.**
3. Check and adjust the orientation of the whole platform compared to the extension plate and vehicle floor. Because the tail lift will decline slightly when loaded, adjust the platform pitch so that the tip is 25.4mm to 50.8mm higher than the extension plate. [Figure 14.2]
4. Adjust the platform pitch using the 2 adjuster bolts at the inboard edge of the platform main section [dim. Y in Figure 14.2]. Loosen the counter nuts, then adjust the bolt length, and retighten the counter nuts. **Make sure both sides are adjusted equally, so that all bolts will support the platform (and its load) evenly.**

WARNING

- Failure to adjust the pitch of the flip-over point and complete platform properly, can cause the cargo to fall off the platform during operation.
- Falling cargo will put the operator and any bystanders at serious risk of bodily injury and death.
- Therefore, it is important that the pitch of the flip-over point and complete platform are adjusted correctly conform with instructions in this manual.

Figure 14.1

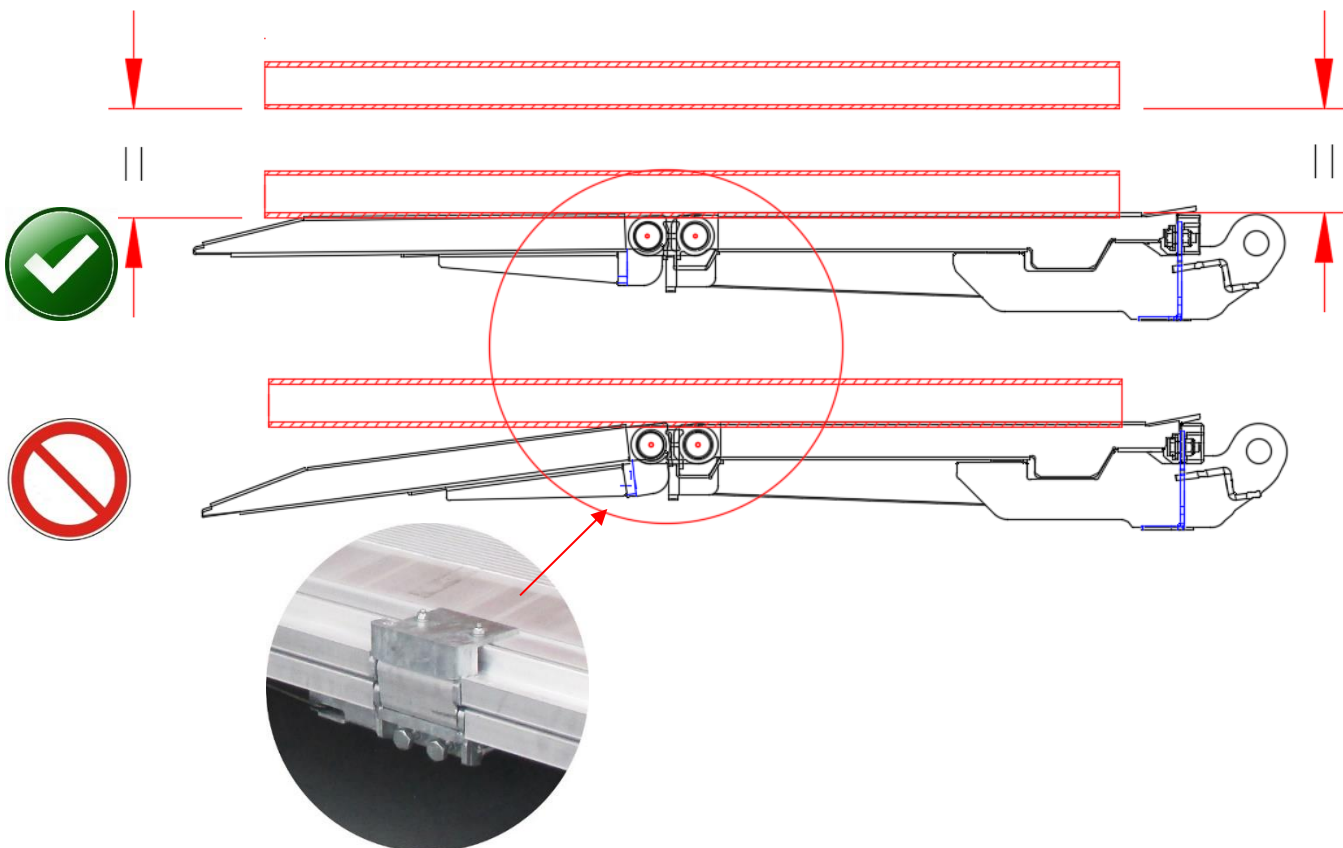
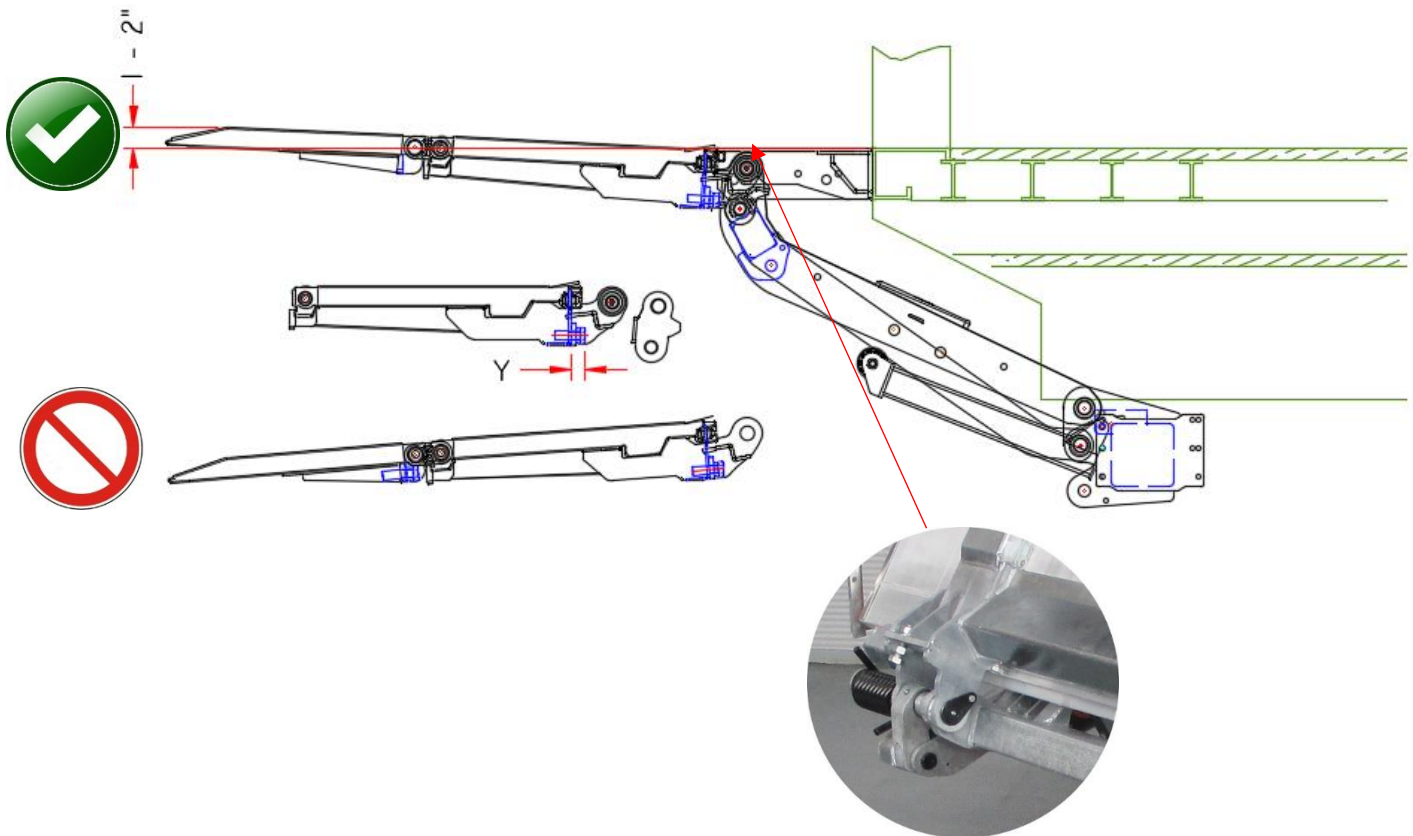

Figure 14.2



15 MOUNTING OF THE SIDE STEPS & DOCK BUMPERS

1. There are 2 possible set-ups [see also drawings in appendix]:
 - I. Side steps directly bolted to floor extension plate by means of 2 bolts M16 [1 in Figure 15.1], to obtain 2430mm overall width (for 2160mm platform width).
 - II. Side steps with intermediate mounting blocks [2 in Figure 15.1], bolted together in 2 subsequent steps by means of 2+2 bolts M16 [1+3 in Figure 15.1] to obtain 2590mm overall width.
2. Bolt the side steps to the floor extension as shown. If a 2590mm extension kit is specified, install the extension kit [2+3 in Figure 15.1] before mounting the side steps.
3. Maintain a 90° angle between the steps and the extension plate. [Figure 15.3]
4. Fasten all bolts and locking nuts to the required torque settings.



Figure 15.1

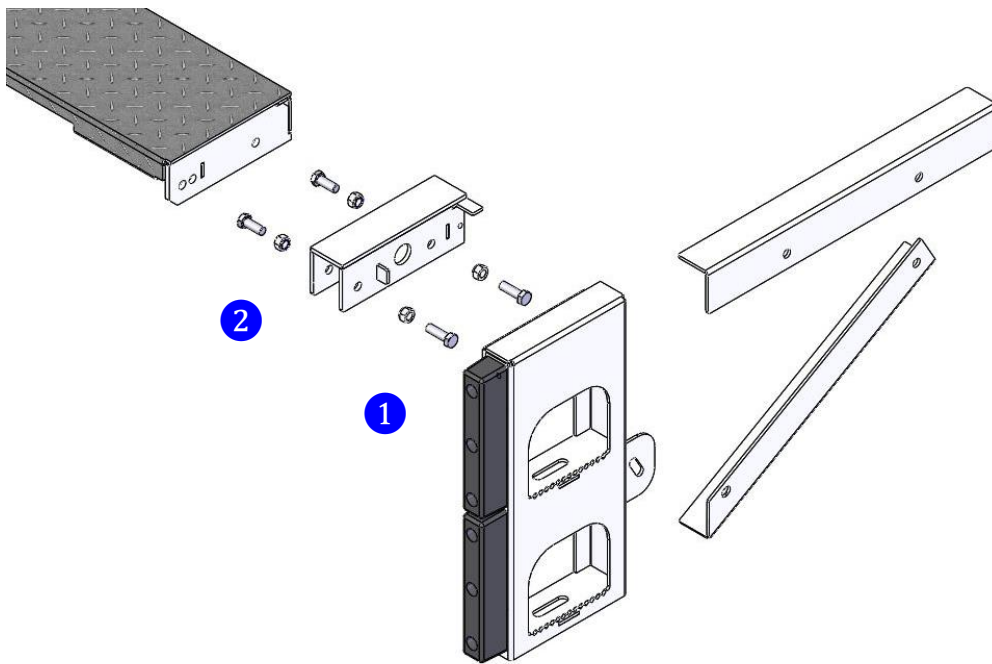

Per side		
1	2x M16x2 (8.8)	195 Nm
2	2x M16x2 (8.8)	195 Nm



Figure 15.2

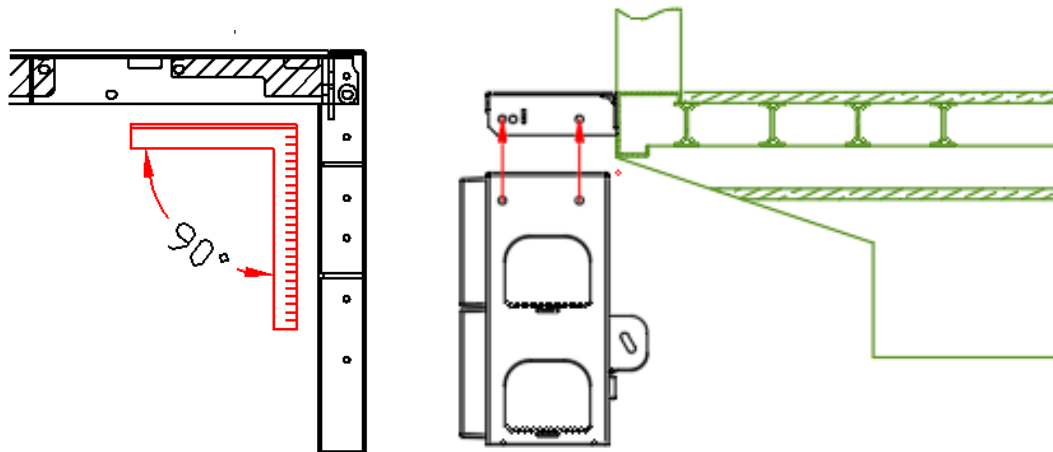

5. Weld the support channels to the rear sill and underside of the I-beam cross members [Figure 15.3]. Weld to as many I-beam or cross members as possible, to distribute the forces of dock impact as much as possible.
6. Clean up the welding seams and apply adequate anti-corrosive coating to protect the body against corrosion. Check, and make sure you comply with the instructions of the OEM vehicle manufacturer.
7. Bolt the diagonal braces between the side steps and support channels on the body [Figure 15.4]. Fasten all bolts and locking nuts to the required torque values.
8. In order to avoid impact damage, it is recommended to have a minimum of 445mm ground clearance; or 10° for vehicles with more than 3m overhang to the centre of the rear axle [fig. 17.4]. For cases with insufficient ground clearance, side steps with a flexible bottom step are available (option ref. OAM057.LR).

Figure 15.3

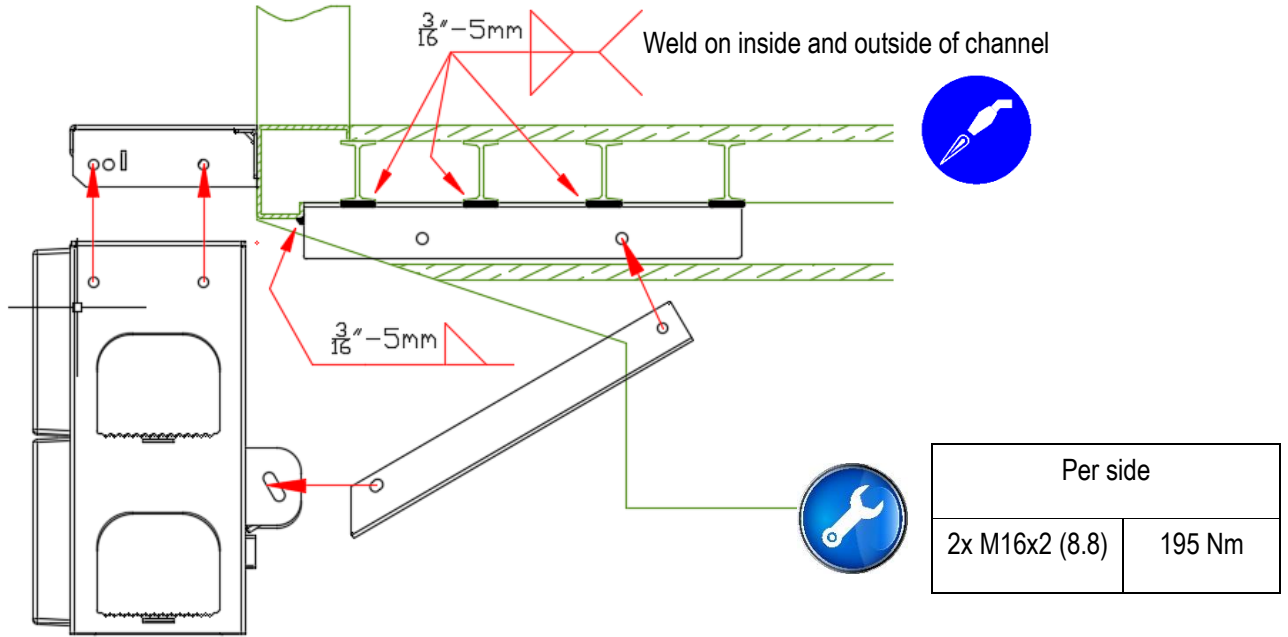
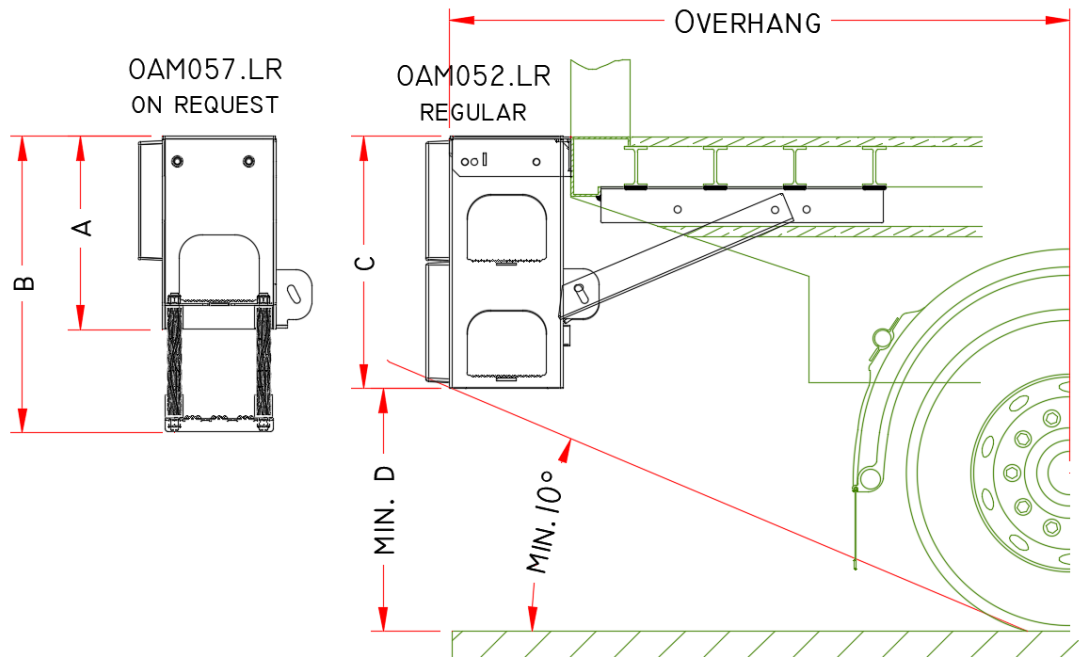

Figure 15.4



Dimensions table	
	mm
A	490
B	750
C	635
D	445

CAUTION



- Before welding, note that welding on galvanized parts releases hazardous fumes. Provide adequate ventilation, and wear an appropriate toxic fume rated welding respirator.
- It is strongly recommended to first grind off the galvanizing in areas where welding is to be done.

NOTICE

Where chassis beams, long sills, the rear sill and other steel chassis or body components have been cut, grinded, drilled, welded etc..., the installer should apply adequate anti-corrosive coating to protect the vehicle and body against corrosion. Check, and make sure you comply with the instructions of the OEM vehicle manufacturer.

16 LUBRICATION INSTRUCTIONS

- All articulation points equipped with lube fittings should be lubricated after installation (pictured on the following page), and once in service with intervals as indicated in the maintenance manual.
- Use a grease gun to pump grease in the lube fittings, until a grease collar is formed on both sides of the bearing or articulation, protecting it against ingress of water, salt, sand and dirt.
- Note that the grease nipple might be located in the pin itself, or in the larger assembly that pivots around the pin.
- In case a pin has 2 grease nipples, grease both sides.
- Ensure all lube fittings function correctly and replace any defective fittings.
- ALWAYS use acid-free grease. The use of graphite grease is not allowed.
- If so equipped, verify if the platform lock operates smoothly, and lubricate with oil if necessary.

NOTICE

To maximize the durability and operational reliability of the tail lift, it is important to lubricate the pivot points thoroughly after installation.

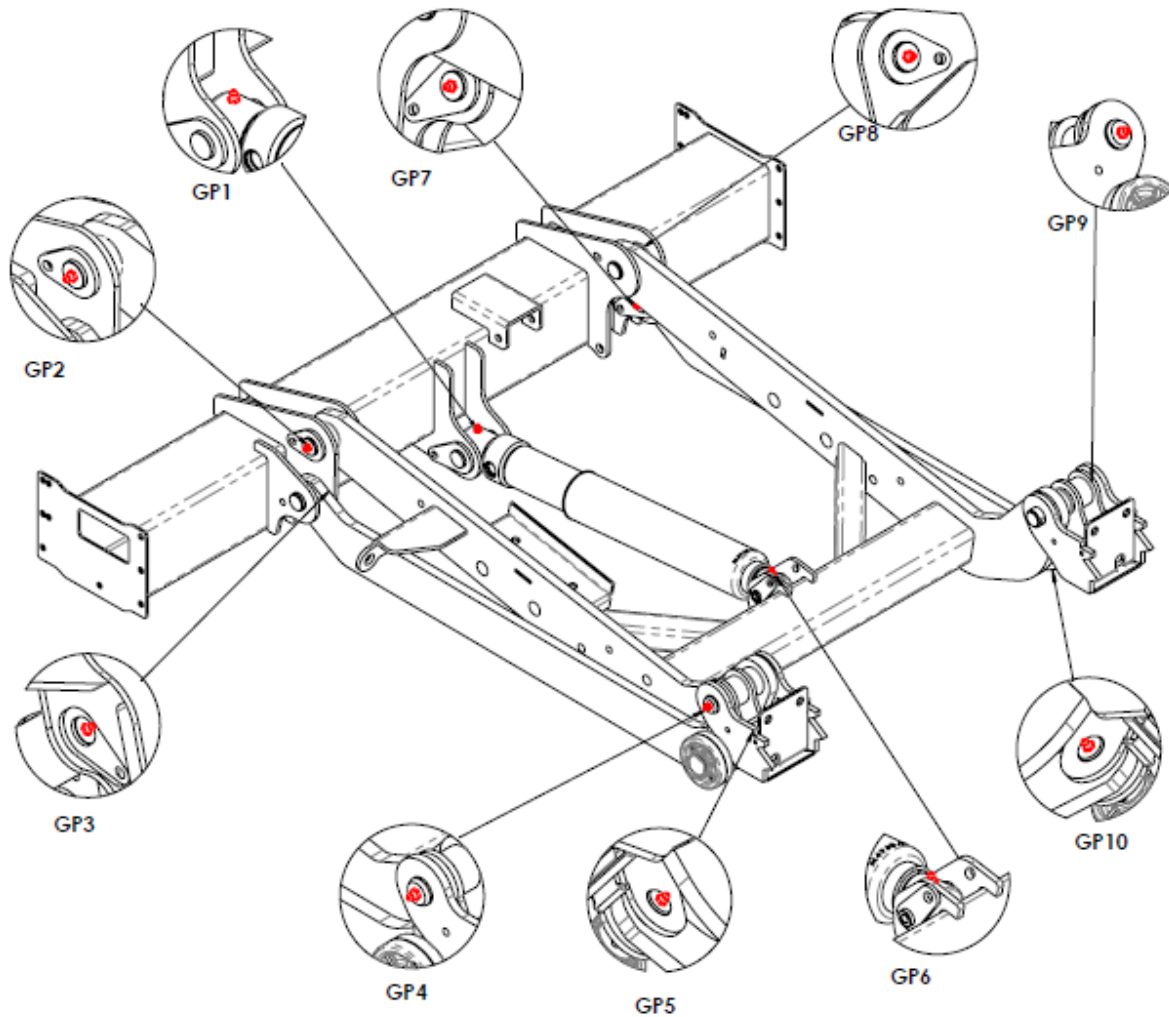

Grease point	Where
GP1	On lift cylinder (center)
GP2	On pin between frame and arm (left side)
GP3	On pin between frame and stabiliser (left side)
GP4	On pin between platform and arm (left side)
GP5	On pin between stabiliser and swing (left side)
GP6	On lift cylinder (center)
GP7	On pin between frame and stabiliser (right side)
GP8	On pin between frame and arm (right side)
GP9	On pin between platform and arm (right side)
GP10	On pin between stabiliser and swing (right side)

17 COMMISSIONING & QUALITY CONTROL

- Finish the tail lift in accordance with local regulations.
- Execute all functions min. 5 times to ensure the tail lift functions correctly. Pay special attention to:
 1. Smooth and quiet operation through the full range of motion of the platform.
 2. Auto tilt at ground level.
 3. Correct alignment of the open platform flush with the extension plate.
 4. Correct stowage of the tail lift in its travel position.
- Make sure that the tail lift will be clearly visible in surrounding traffic [Figure 17.1]:
 1. Apply the RD/WH visibility tape on both sides of the platform.
 2. Fit the platform flags to the underside of the flip-over point.
 3. If applicable: connect the flashing platform lights (if not prewired) and verify their function.
- If the operator is allowed to travel up and down on the platform, it is strongly recommended to paint a safe-work zone of 400mmx400mm at a safe distance of 250mm removed from the hazardous crushing area between the inboard platform edge and the extension plate. [Figure 17.2]
- Work through the PDI checklist in the appendix and complete the practical load tests indicated. Fill-out the FITTING DECLARATION.
- During weight test, verify if the hydraulic pump pressure suits the maximum rated lift capacity in this particular mounting situation. Adjust the pressure if too high or too low, seal the pressure relief valve after that using the provided tamper-evident cap.

Figure 17.1

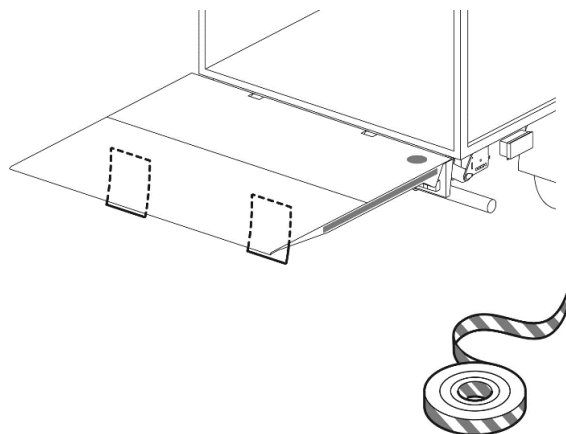
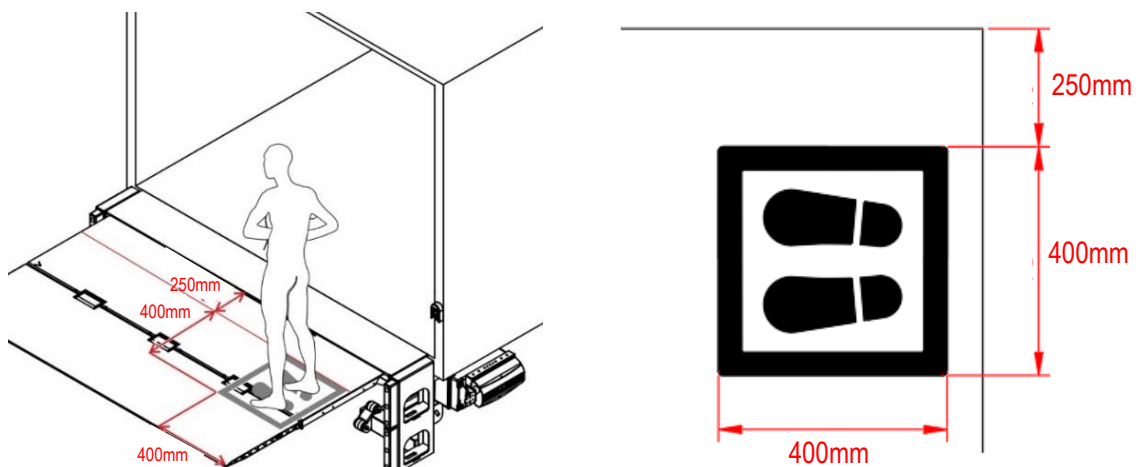

Figure 17.2



18 DECALS

18.1 REGULAR DECALS

1. The following decals are supplied with each new tail lift and should be affixed to the vehicle body during installation in the manner set forth in the adjacent drawings.
2. NEVER remove or paint over any decal. Missing, worn or illegible warning decals MUST be immediately replaced. Get free replacement decals from DHOLLANDIA. Contact your regional DHOLLANDIA distributor. See page 4 for contact info.
3. The operator should comply with all affixed safety and instructions decals. Be aware that the decals merely summarize the main points, and that the operator MUST know, understand, and comply with the full contents of the operation manual.
4. Note: the decals marked as “EXAMPLE” can vary in function of the maximum rated capacity of the tail lift, or the chosen type of external control box.

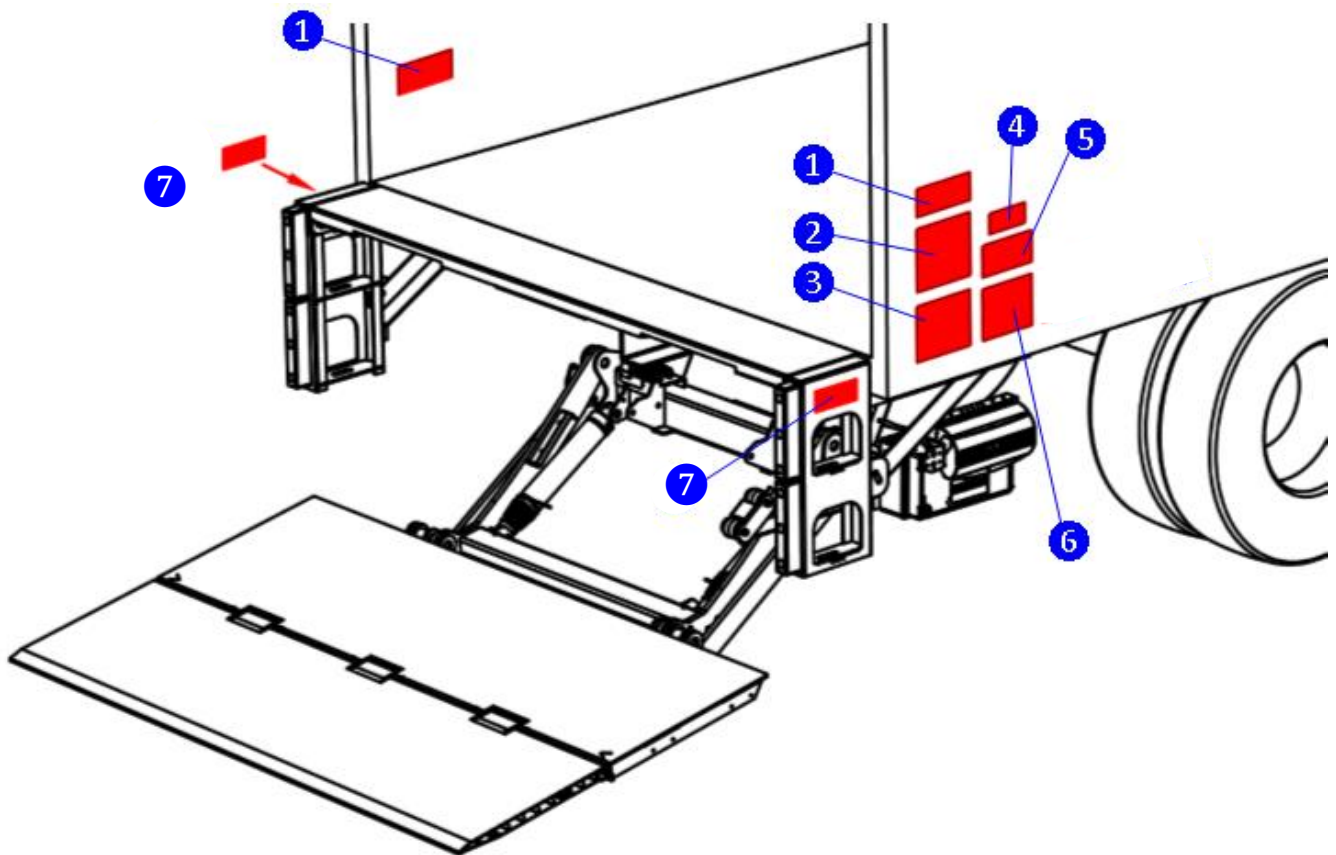

NOTICE

Remove any unwanted debris or residue from surfaces before installing any of the decals to ensure proper adhesion.

1

EF0583.RM.EN

⚠ WARNING

- DO NOT use this liftgate without adequate safety and operator training.
- View safety and operation video prior to use. Use this QR-code to connect.
- Review operation manual prior to use. Manuals can be obtained from your DHOLLANDIA distributor, or downloaded from: www.dhollandia.com
- Improper use of the liftgate will put the operator and other parties at great risk of bodily injury and death.
- In case of doubt, contact DHOLLANDIA toll free:

US West: 855 856 8225 US East: 855 894 1888 CAN: 888 750 5438



DHOLLANDIA • EF0583.RM.EN

2

EF0565.EN

⚠ WARNING - SAFETY INSTRUCTIONS

 Read and understand the user's manual, all instructions and warnings before use.

Carelessness or ignorance will put the operator and third parties at great risk of serious injury and death.

- Do not use liftgate unless you have been properly trained and instructed, you have read and you understand the full operating instructions.
- Wear appropriate working clothes, incl. footwear with steel toe caps and a good non-slip sole, and wear protective gloves.
- Ensure the vehicle is safely parked and braked before using the liftgate.
- Where applicable, refer to the site's specific risk assessment, and follow the local work & safety instructions.
- Always inspect the lift gate before using it. DO NOT use liftgate if there are signs of bad maintenance, subnormal wear or damage, or if the platform surface is slippery. DO NOT attempt to repair liftgate yourself, unless you have been trained and authorized to do so.
- Do not overload. Observe the maximum rated capacity and load charts.
- Do not stand behind or within reach of the platform.
- Make sure that platform area, including the area in which loads may fall from platform, is clear of obstacles and other people at all times.
- Make sure you can see and keep visual control over the whole working area of the liftgate, the platform and its load at all times.
- Beware of finger and toe traps at all times. When riding platform, stand at safe distance of minimum 10" from the inboard edge of the platform adjacent to the rear sill of the vehicle body.
- It is prohibited for anyone other than the operator to travel on the platform.
- Liftgate is intended for loading and unloading cargo only. Do not use liftgate for anything else but its intended use.
- Make sure platform is clearly visible from all approach directions (by means of flashing platform lights, platform flags, traffic cones, etc...) and that the working zone is sufficiently illuminated.

3

EF0618.EN

OPERATION INSTRUCTIONS

Read and understand the operation manual and all safety decals before operating this liftgate. Improper use can put the operator and other parties at great risk!

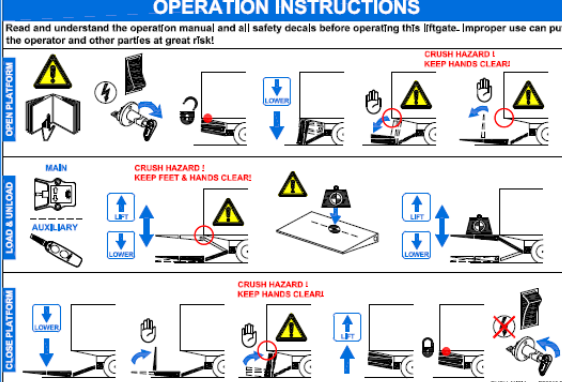

DHOLLANDIA • EF0618

4

EF0570.CAP

MAX. XXXX kg

EF0570.00500

5

EF0564.EN

PLATFORM LOADING INSTRUCTIONS

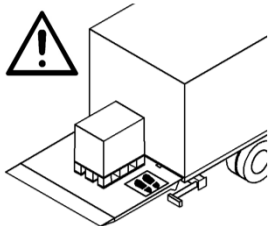

Position load as close as possible to inboard platform edge. Position load in middle line of platform. Avoid loading on 1 side only. Operator should stand on side of load, well clear of inboard platform edge to avoid crushing feet.

Read and understand the user's manual, all instructions and warnings before use.

DHOLLANDIA • EF0564

6

EF0563.EN

⚠ WARNING



Liftgate hazards can result in crushing or falling. Keep hands and feet clear of pinch points. If riding liftgate, make sure load is stable and footing is solid.

 Read and understand the user's manual, all instructions and warnings before use.

DHOLLANDIA • EF0563

7

EF0562.EN

⚠ WARNING

Always stand clear of platform area.

DHOLLANDIA • EF0562

A

EF0814-EN-US



DHOLLANDIA • EF0814.EN.US

B

EF816.ENFR



C

EF817.ENFR



LIFTGATE DECALS USED AND AFFIXED IN AREAS, OTHER THAN THE REAR OF THE VEHICLE:

- A Cabin switch in driver's cabin to switch electrical power to liftgate on / off (if so equipped)
- B For circuit breaker in liftgate battery compartment
- C For main fuse in liftgate battery compartment





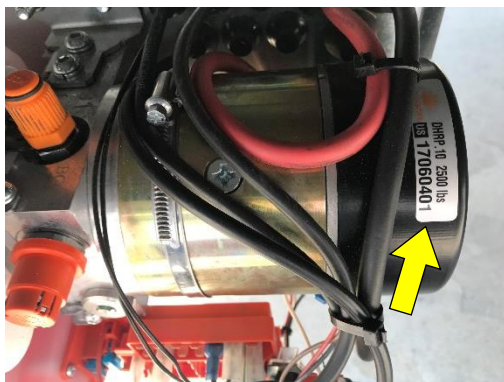
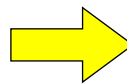
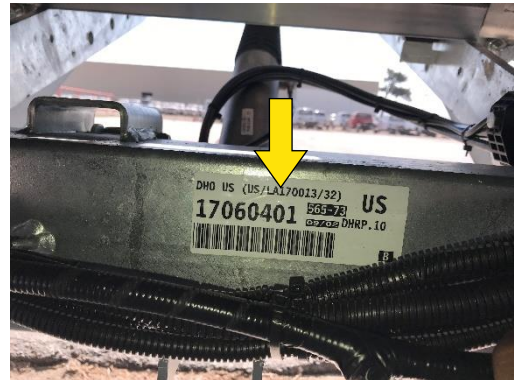
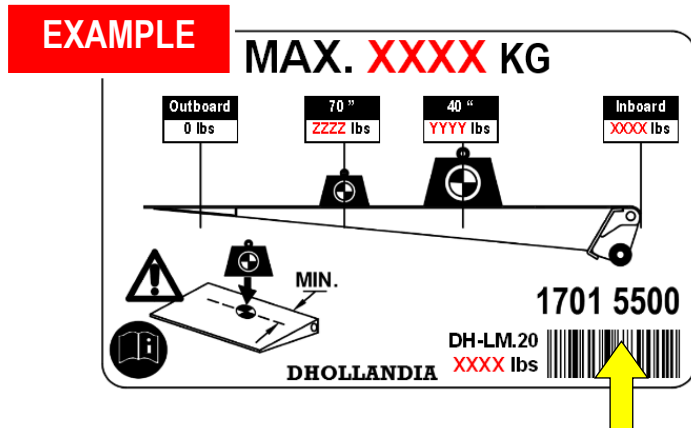



18.2 IDENTIFICATION DECALS

1. Every DHOLLANDIA tail lift is identified and labelled with a unique 8-digit serial number (with or without a space between the first and last 4 digits). This number is used for any inquiry on a particular tail lift, or when ordering replacement parts.
2. In addition to the tail lift type and serial number, the various serial number labels provide additional information such as: the maximum rated lift capacity and load chart, the bumper certification number, the date of manufacture, etc...
3. The labels are usually affixed to the vehicle body and various tail lift components and can be found in the locations shown in the images below.







19 APPENDIX











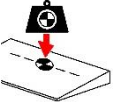

19.1 DECALS

WARNING signs	
	Overview and keep visual control over the working area of the tail lift at all times.
	General warning sign used to alert the user to potential hazards. All messages that follow this sign shall be obeyed to avoid possible harm.
	Entrapment hazard. Keep hands, limbs, loose clothes and long hair away from moving parts.
	Crushing & shearing hazard. Keep hands away from moving parts.
	Crushing & shearing hazard. Keep feet away from moving parts.
	Slipping hazard.
	Tripping hazard.
	Hazard caused by tilting objects.
	Hazard of falling from heights.

MANDATORY ACTION signs	
	Contact your regional DHOLLANDIA distributor.
	Consult the DHOLLANDIA website. Download from DHOLLANDIA website.
	Read the manual or instructions.
	Hold onto safety rail. Protect yourself from falling off the platform, or vehicle floor.
	Wear safety gloves.
	Wear safety-toe shoes.
	Wear appropriate work clothes, avoid loose-fitting clothes that might be trapped in the moving parts of the lift.
	Wear safety protection, eye protection and a safety hard hat.
	Use a safety shield.

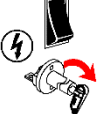
PROHIBITION signs			
	General prohibition. DO NOT do!		DO NOT use machine by more than 1 operator!
	General prohibition. DO NOT do!		DO NOT step or stand here!

Other frequently used signs

	Yes do this way. Correct work procedure.
	Yes do this way. Correct work procedure.
	No, DO NOT do this way. -Incorrect work procedure.
	Position the load at the applicable centre of gravity or load centre. - Follow the load instructions.
	Emergency stop. Will cause an immediate stop of the tail lift.
	Emergency exit. Provision (lever, valve,...) creating an emergency exit.
	Unlock. Disengage the mechanical locking system.
	Lock. Engage the mechanical locking system.
	Switch ON the electrical power.
	Switch ON the electrical power to the tail lift via the main battery disconnect switch and / or cabin switch.
	Switch OFF the electrical power.
	Switch OFF the electrical power to the tail lift via the main battery disconnect switch and / or cabin switch.
	This is an operation to be executed manually (as opposed to an electrical function controlled by means of one of the control units).

19.2 PRESCRIBED TORQUES VALUES FOR BOLTS SUPPLIED WITH TAIL LIFT

- Installer **MUST** verify that all bolted connections are fastened with required torque in conformance with table in this appendix.
- After weight testing, installer **MUST** verify that all bolted connections between lift frame and mounting plates, and between mounting plates and vehicle chassis are still tightened in conformance with required torque. Retighten if required.
- Use a calibrated torque wrench to tighten bolt and nut connections to the prescribed torque value.

NOTICE



WARNING

- Incorrect, too soft or too hard tightening of mounting bolts can lead to accidental fall of the tail lift off the vehicle chassis.
- A fall of the tail lift off the chassis can damage the tail lift and / or vehicle chassis and can cause serious bodily injury or death to the operator and any bystanders.
- Therefore, it is essential that the mounting plates are installed following the instructions of this manual.



Prescribed torque values M in N.m

Type of thread	Size	Strength class			
		<u>8.8</u>		<u>10.9</u>	
Standard	M6 x 1	10	N.m	14	N.m
	M8 x 1.25	24	N.m	33	N.m
	M10 x 1.5	47	N.m	65	N.m
	M12 x 1.75	82	N.m	115	N.m
	M14 x 2	129	N.m	185	N.m
	M16 x 2	195	N.m	285	N.m
Fine	M14 x 1.5	135	N.m	185	N.m
	M16 x 1.5	208	N.m	265	N.m
	M20 x 1.5	175	N.m	-	N.m
	M24 x 2	185	N.m	-	N.m

Prescribed torque values M in lbs-ft

Type of thread	Size	Strength class			
		8.8	-	10.9	-
Standard	M6 x 1	7.5	lbs-ft	10.5	lbs-ft
	M8 x 1.25	17.5	lbs-ft	24.5	lbs-ft
	M10 x 1.5	34.5	lbs-ft	48	lbs-ft
	M12 x 1.75	60.5	lbs-ft	85	lbs-ft
	M14 x 2	95	lbs-ft	136.5	lbs-ft
	M16 x 2	143	lbs-ft	195	lbs-ft
Fine	M14 x 1.5	99	lbs-ft	136	lbs-ft
	M16 x 1.5	155	lbs-ft	195	lbs-ft
	M20 x 1.5	129	lbs-ft	-	lbs-ft
	M24 x 2	136	lbs-ft	-	lbs-ft

19.3 PDI CHECKLIST 1/2

1 - General inspection on the fitting parameters	
The vehicle is technically suitable for the type of lift and its max. rated capacity.	
The requirement for mechanical or hydraulic stabilizing legs has been checked and been fulfilled (if applicable).	
The actual fitting dimensions don't exceed the theoretical maximum fitting dimensions mentioned in the fitting drawings.	
The lift has been fitted to conform with the fitting instructions of DHOLLANDIA, and the Body Building Guidelines of the OEM vehicle manufacturer.	
All safety decals have been affixed in conformance with the installation instructions and are clearly legible.	

2 - Inspection of the mechanical part	
The size, number and spread of mounting bolts conform with the installation instructions. All bolts are fastened to the prescribed torque values. Check for potential deformation of the mounting bolts and plates after weight testing.	
The extension plate, side steps, braces and dock bumpers are installed in conformance with the installation instructions.	
All welding has been performed by qualified welders.	
All articulation pins and retaining bolts are properly fastened and secured.	
All articulation pins are equipped with lube fittings and are lubricated.	
Areas of drilling, cutting, grinding, welding etc. are adequately protected against corrosion.	

3 - Inspection of the electrical part	
Voltage of the lift is compatible with voltage of the vehicle. The batteries & alternator suit the lift capacity, application & frequency of use.	
The cabin switch in the driver's cabin, and the main battery isolator switch of the external control box (whichever is applicable) function OK.	
The main fuse or circuit breaker, the battery and ground cables are fitted correctly and conform to the fitting instructions, all bolted connections of cables and fuses are properly tightened and secured.	
All electrical connections are coated with dielectric grease.	
The position of the exterior control box conforms to the fitting instructions.	
The power feed to all auxiliary controls is wired into the safety switch on the main external control box (if so equipped). When the external control box is active, none of the auxiliary control units are activated, and vice versa.	
The "hold-to-run" principle works on all control units: any ongoing movement should immediately stop when one of the corresponding switches is released.	
The cables going to the platform (flashing lights, foot controls, ...) are properly routed, and cannot be damaged during the various movements of the lift.	

The electrical platform mounted options (flashing lights, foot controls, etc.) function properly.	
---	--

4 - Inspection of the hydraulic part	
There are no visible oil leaks after the load test tests in operation and at rest.	
The visible oil level corresponds with the oil level instructions of this manual.	
The hydraulic circuits have been purged to remove any remaining air.	
During the various movements of the lift, the flexible oil pipes stay clear from the vehicle chassis & body. They cannot be damaged by rubbing, squeezing, etc.	
None of the thermoplastic pipes has been damaged or marked during welding.	
The cover of the pump unit is mounted and securely latched.	

5 - Inspection of the platform	
The centre point of maximum load is correctly marked and corresponds with the data mentioned on the identification sticker supplied with the tail lift.	
The safe working zone for the operator is clearly and permanently marked on the platform (if applicable). The provided foot protection conforms with the fitting instructions.	
The platform is made sufficiently visible for the surrounding traffic (platform lights, flags, reflective tape, traffic cones,...)	
At vehicle floor level, the platform aligns flush with the extension plate.	
A hand grip for the operator to hold when lifting / lowering with the platform, is mounted on the rear frame of the vehicle body.	

7- General operation, practical tests	
<p>Unfolding and folding test:</p> <p><input type="checkbox"/> The platform opener is mounted in adequate position. When LOWERED at the ground, the platform stands just inside from vertical position.</p> <p><input type="checkbox"/> The platform unfolds and folds without touching the vehicle chassis.</p>	
<p>General operation with an empty platform: execute all movements several times with ALL available control units. The tail lift should work smoothly and quietly, and almost silently, through its full range of motion.</p> <p><input type="checkbox"/> Gravity down lifts: during LIFT, only the sound of the running DC motor in the pump unit should be audible.</p> <p><input type="checkbox"/> Power down lifts: the sound of the running DC motor in the pump unit will be audible during LIFT and LOWER movements.</p> <p><input type="checkbox"/> Any other (creaking, grinding or squeaking) noise should be carefully investigated and solved.</p>	
<p>Dynamic test at 100% of maximum rated lift capacity:</p> <p><input type="checkbox"/> Verify if the lift has sufficient lift capacity.</p> <p><input type="checkbox"/> Verify the general performance & stability.</p>	

<p>Overload test - Limitation of the lift capacity:</p> <ul style="list-style-type: none"> <input type="checkbox"/> Place the platform at rest on the ground. <input type="checkbox"/> Put a load of 1x maximum rated lift capacity at the centre point of maximum load; adjust the hydraulic pressure on the pressure relief valve so that the maximum rated lift capacity is just reached. Seal the pressure relief valve after final adjustment with the provided tamper-evident cap. <input type="checkbox"/> Put a load of 1.25x maximum rated lift capacity at the centre point of maximum load. The platform should not be able to lift vertically. 	
---	--

8- Documentation for the operator	
The OPERATION MANUAL and MAINTENANCE MANUAL are available in the vehicle.	

<i>NOTICE</i>	 WARNING
<ul style="list-style-type: none"> The PDI check-list completes the final quality inspection of the installation. Once completed successfully, it will certify the safe and reliable operation of the tail lift. Operating a tail lift that hasn't successfully passed the PDI can lead to premature wear or damage of the tail lift itself. Operating a tail lift that hasn't successfully passed the PDI can put the operator and third parties at great risk and could result in serious personal injury or death. It is therefore essential that the PDI check is completed with due diligence, and any shortcomings rectified prior to delivery of the vehicle to the operator. 	

19.4 SAFE OPERATOR POSITION ON THE PLATFORM



- Consult the OPERATION MANUAL section 7.
- The operator travelling up and down on the platform, faces 2 main risks:

- The operator travelling up and down on the platform, faces 2 main risks:



- i. Falling from the platform. Falling from the platform can result in serious body injury or death
- ii. Risk of crushing and shearing the limbs between the raising platform and the rear of the vehicle floor or extension plate. Crushing or shearing limbs or body parts can will result in serious bodily injury.

- To reduce the risk that the operator falls from the platform, DHOLLANDIA recommends that the installer mounts a handgrip to the rear frame of the vehicle body. Such handgrip will enable the operator to ALWAYS maintain 3 points of contact while lifting or lowering on the platform. [Figure 19.1]
- The handgrip is normally manufacturer by the upfitter or body builder as part of the design of the box, but an alternative is available from DHOLLANDIA with ref. M1406. [Figure 19.2]
- To reduce the risk that the operator crushes his feet between the raising floor and the end of the vehicle floor, DHOLLANDIA recommends that the installer paints a 400mmx400mm safe operator position at a safe distance of min. 250mm away from the inboard platform edge. [Figure 19.3]
- A metal paint mask can be ordered from DHOLLANDIA with spare parts ref. EF0100.

Figure 19.1

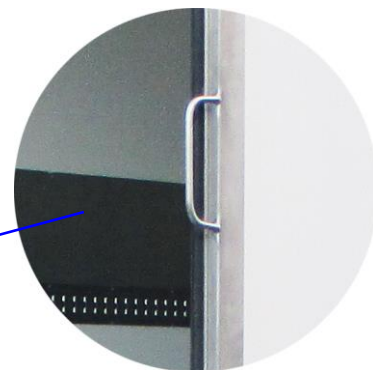
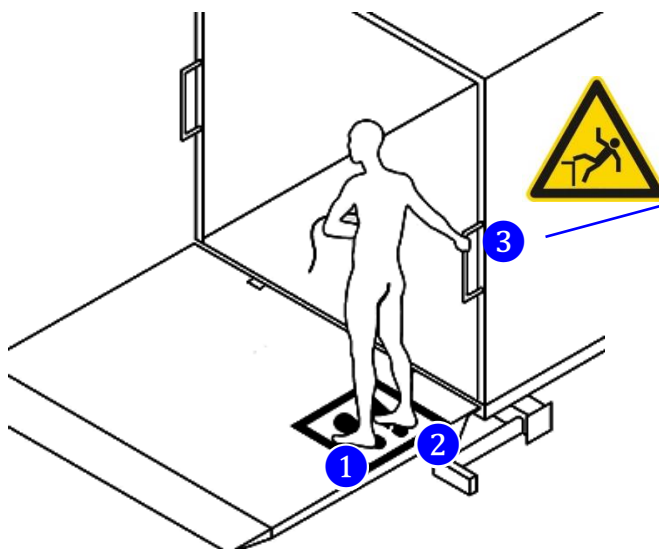
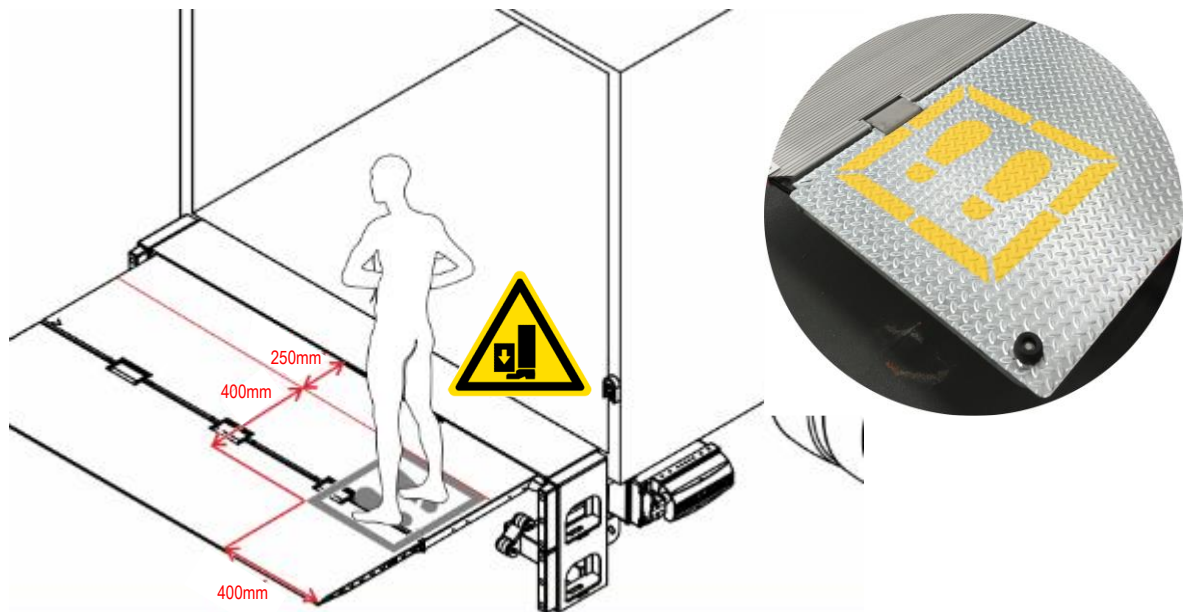

Figure 19.2



Figure 19.3



19.5 2-BUTTON PORTABLE CONTROL

- The optional 2-button handheld control [1 in Figure 19.4] with spiral cable is supplied with a plug premounted on the spiral cable [4 in Figure 19.4], and a socket [5 in Figure 19.4] that is installed during the installation of the tail lift.
- Mount the socket [5] in the top corner of the vertical body panel, or other position where it is protected against physical damage. [Figure 19.4]
- Mount the socket [5] vertically to minimize the impact of accidental water ingress. [Figure 19.5]
- Route the cable [6] of the socket to the pump unit and connect it according to the wiring diagram supplied with the tail lift.
- Make sure the cable [6] is protected against physical damage. Run the cable inside the rear post of the vehicle body or mount a steel protection plate over it.
- If the tail lift is equipped with a main external control box (with compulsory 2-hand control), other than the toggle-switch described in this manual, wire the power feed of the 2-button portable control into the safety button of that control box in conformance with the wiring diagrams.
- Mount the holder [2] for the handheld control [1] in a position that is as much as possible protected against physical damage, and within reach of the operator. The handheld control [1] is also equipped with a magnet, so that it will stick to any metal surface.
- Mark the safe operator position on the platform and mount a hand grip to the rear frame of the vehicle body in conformance with Appendix 4.

Figure 19.4

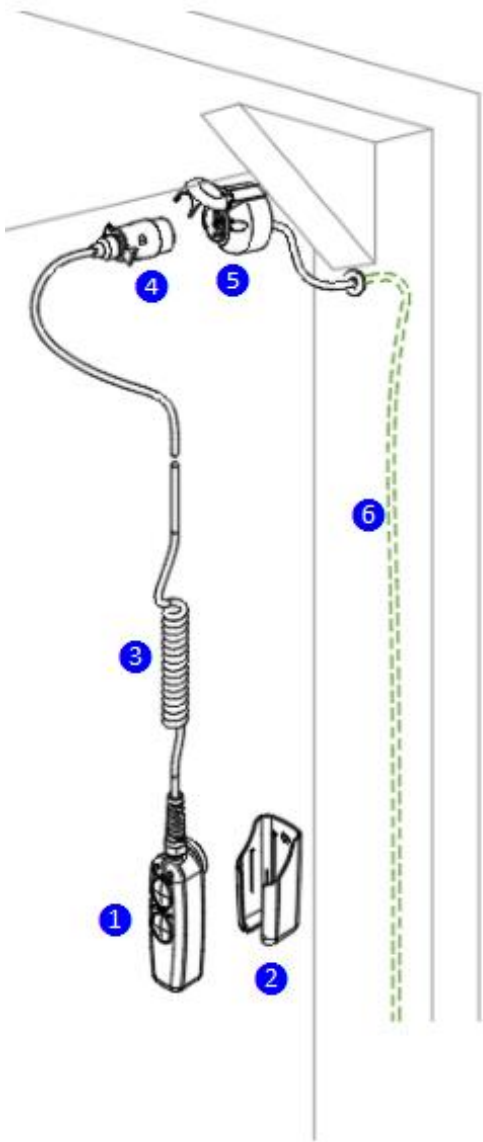
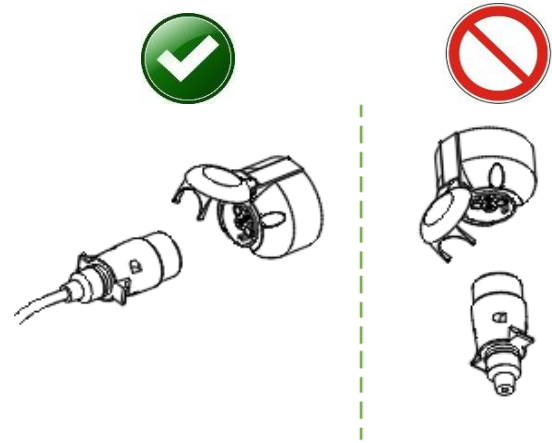
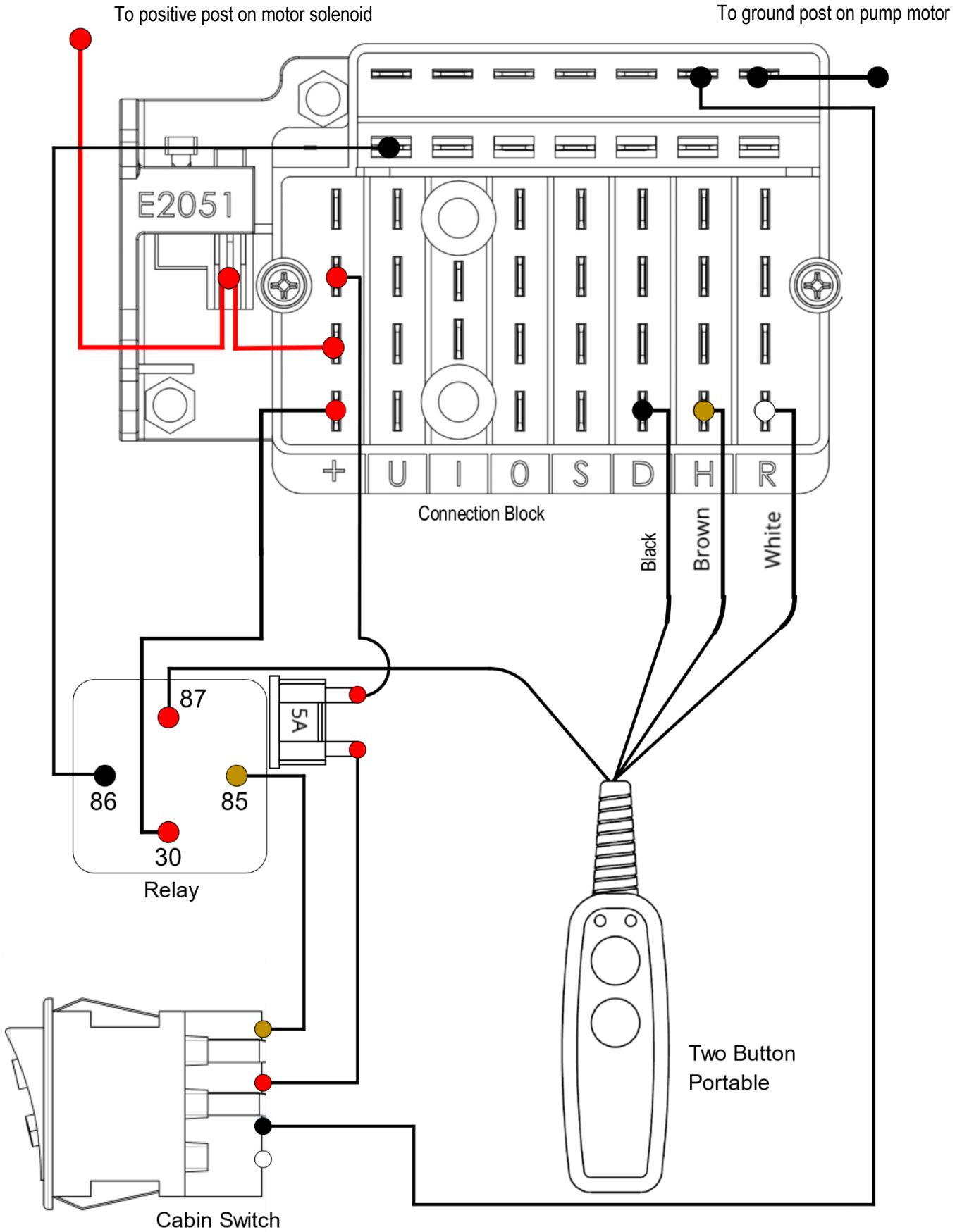

Figure 19.5



- A general wiring schematic for **gravity down** with the two-button handheld control is shown in Figure 19.6.

Figure 19.6



- For option OAE510.15, see Figure 19.7, below:

Figure 19.7

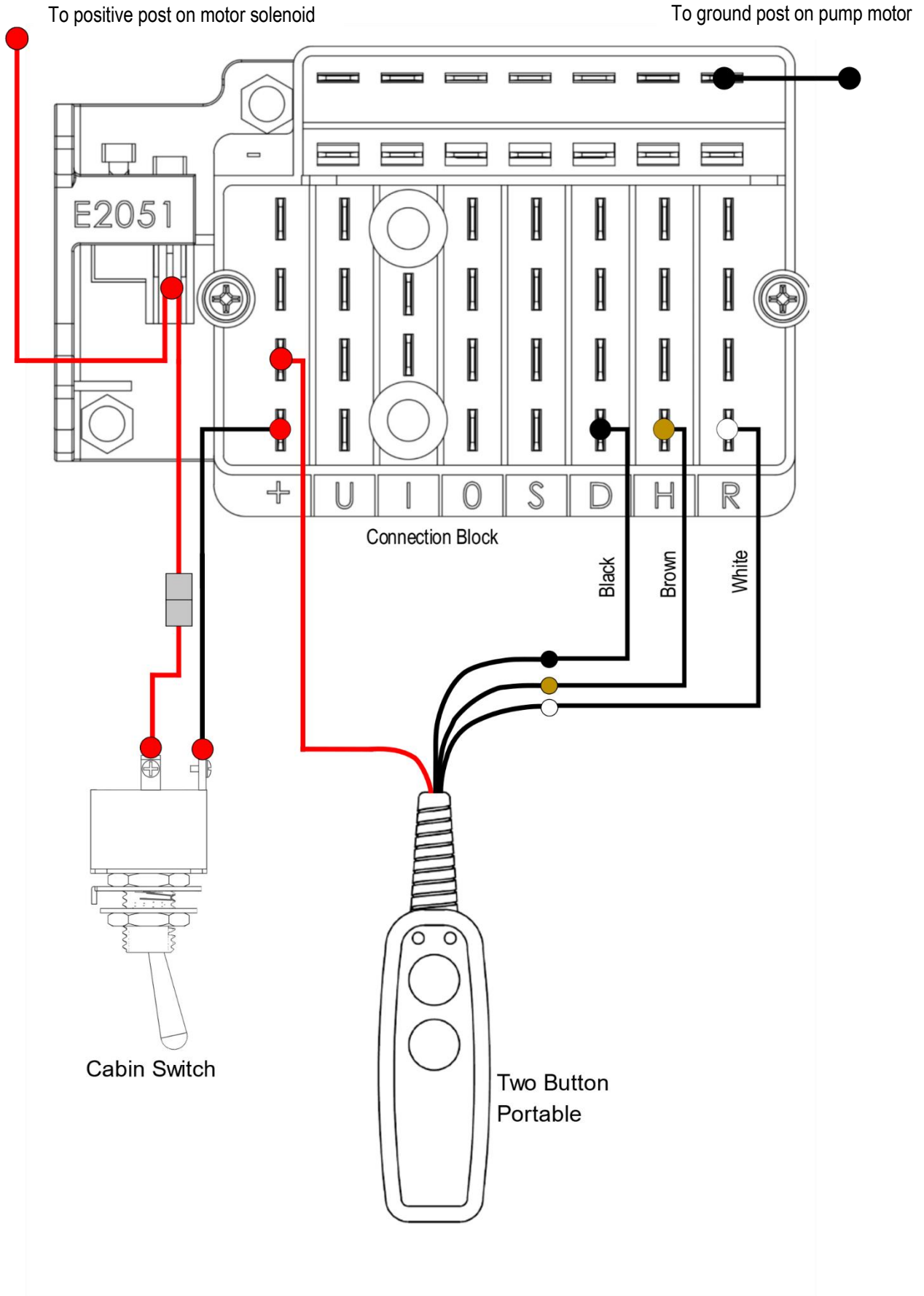

- A general wiring schematic for **power down** with the two-button handheld control is shown in Figure 19.8.

Figure 19.8

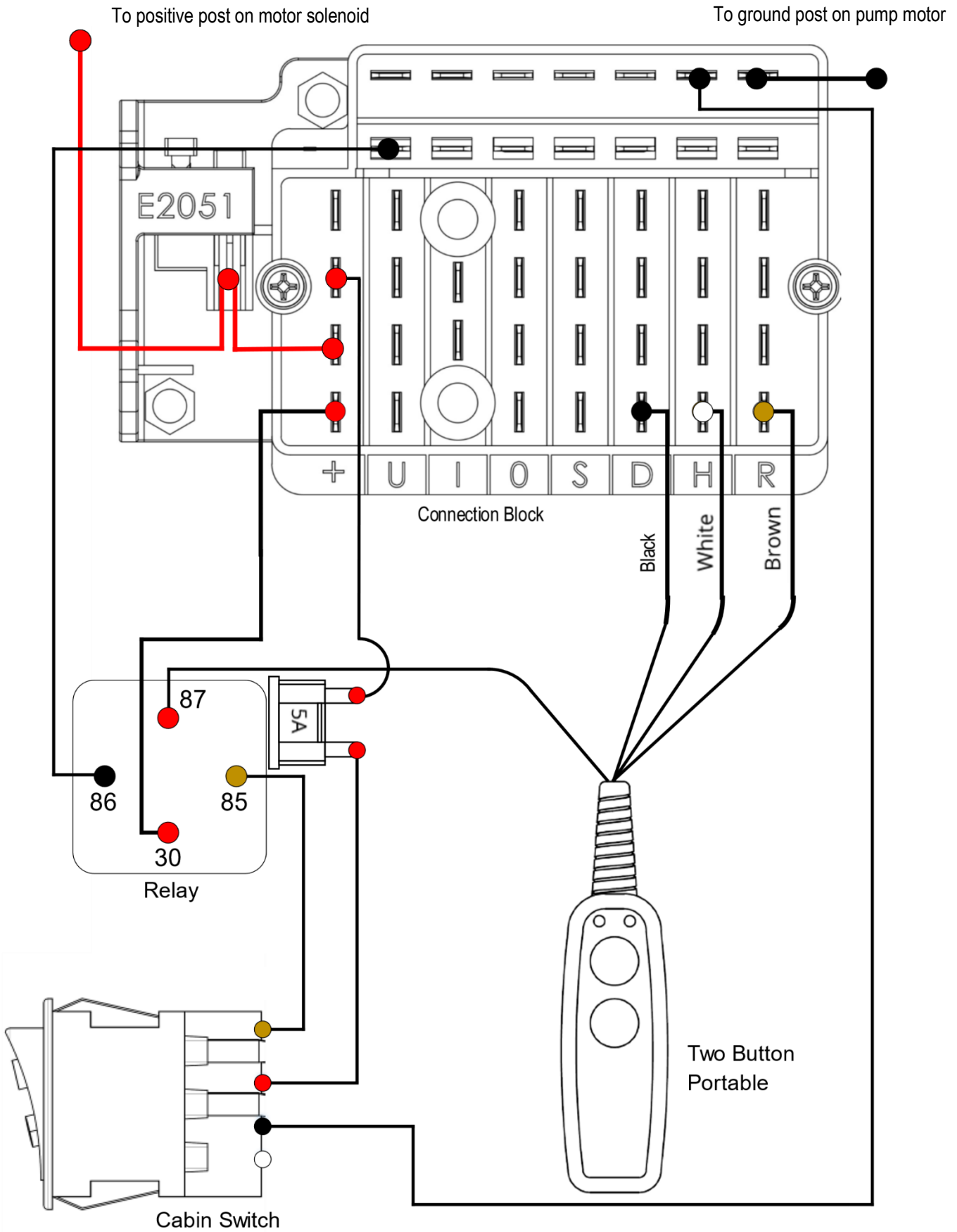

- For option OAE510.15, see Figure 19.9, below:

Figure 19.9

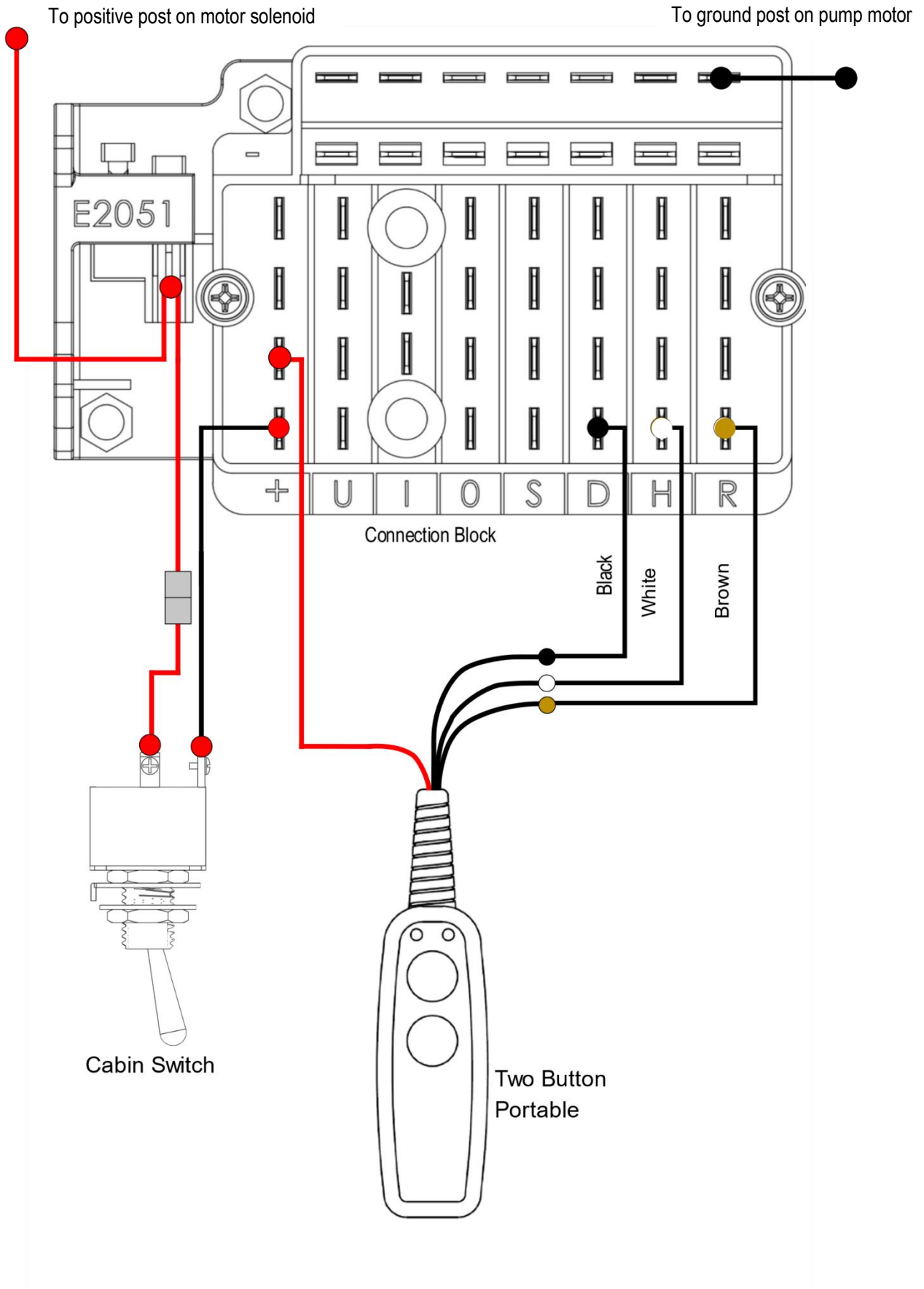

19.6 CIRCUIT BREAKER

- A resettable circuit breaker option is also available for the connection to the batteries. [Figure 19.10]

Figure 19.10

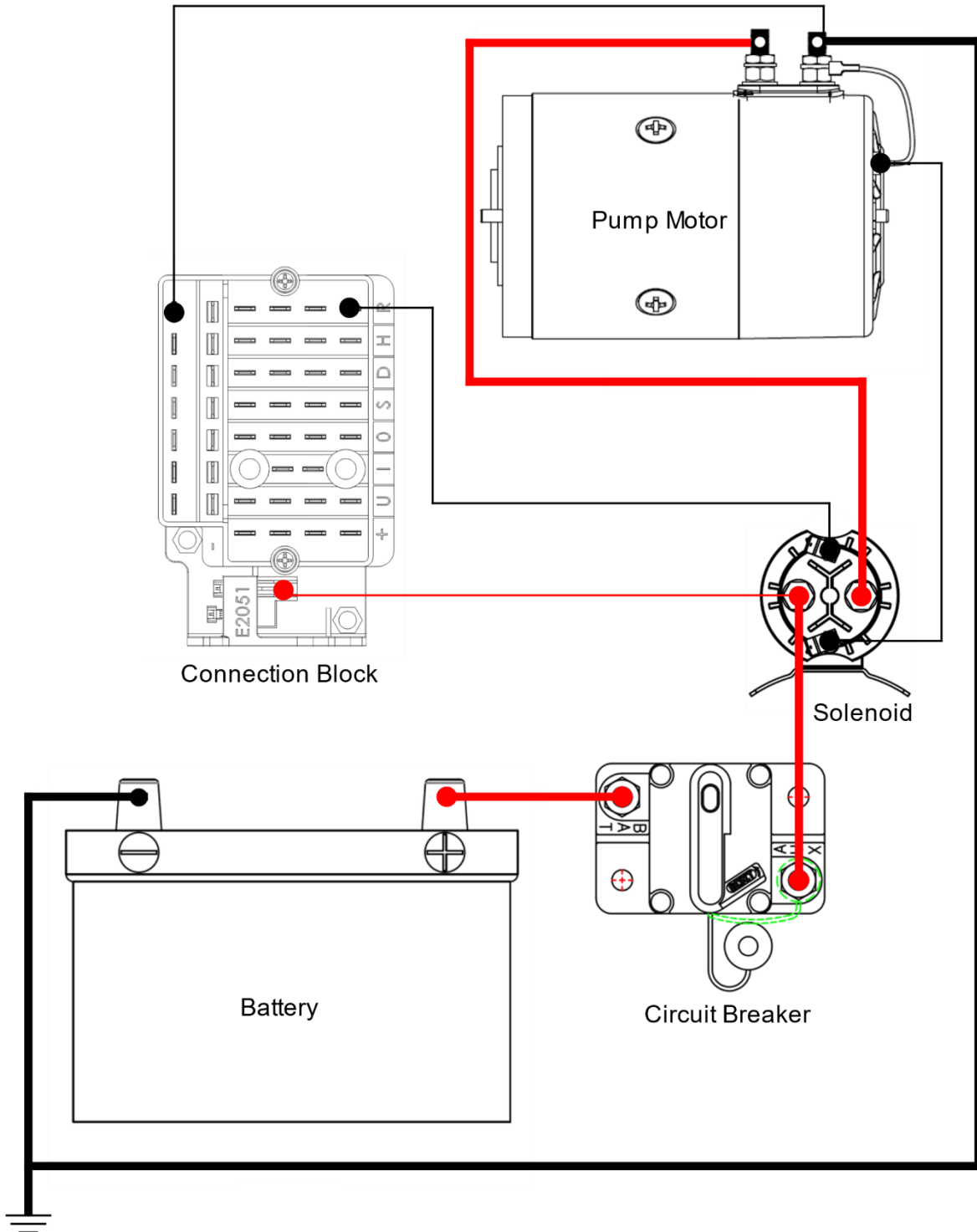

19.7 CAB CUT OFF SWITCH

- Refer to the appropriate connection sequence in Figure 19.11 to properly connect the E0667 illuminated cab switch.

Figure 19.11

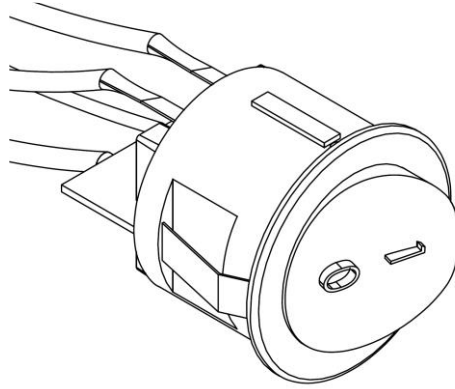
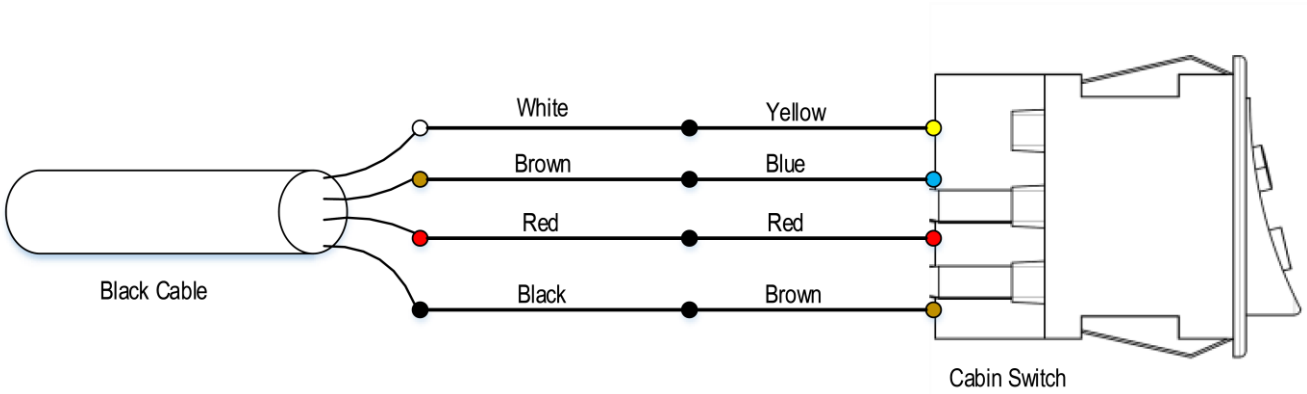
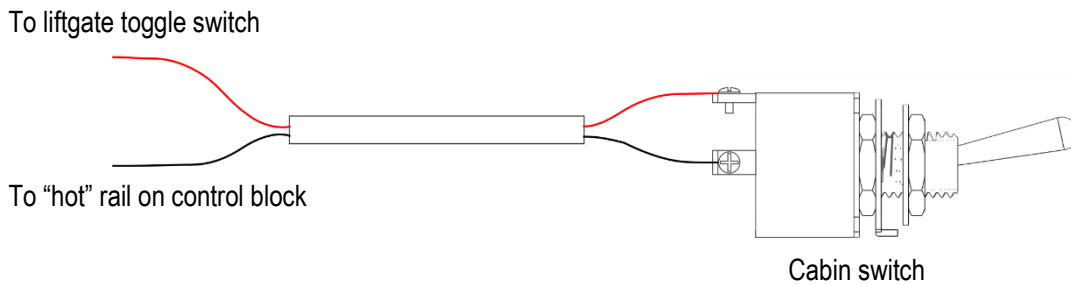

Figure 19.12



- For orders that shipped with option OAE510.15, refer to Figure 19.13 to properly connect the cab switch.

Figure 20.13



19.8 ELECTRIC AND HYDRAULIC INFORMATION

- Because of the wide choice in different control boxes and electrical options, ANNEX 3 only includes the basic diagrams for fully standard tail lifts.
 - The correct diagram applicable for the tail lift supplied can be found on the inside of the control box. If correct diagram is not present inside control box, contact the national DHOLLANDIA distributor for further assistance, or download from the website.
 - Other important information sources available on the website
 1. FIT-ELEC-GENERAL-.. (latest update) for installation of main control box, battery and ground cables
 2. FIT-ELEC-OPTION-.. (latest update) for installation of extra controls and electrical options
- Remark: the following minimum cable sections are recommended (+) battery cables and (-) ground cables

Recommended MIN. cable sections for (+) battery cables and (-) ground cables	
Size electric motor	Cable section
500 W	16 mm ² - 5 AWG
1200 - 2200 W up to max. 1500kg capacity (length ≤ 7m)	25 mm ² - 3 AWG
1200 - 2200 W up to max. 1500kg capacity (length > 7m)	35 mm ² - 1 AWG
1200 - 2200 W above 1500kg capacity (length ≤ 13m)	35 mm ² - 1 AWG
1200 - 2200 W above 1500kg capacity (length > 13m)	50 mm ² - 0 (1/0) AWG
3000 W (only 24V)	35 mm ² - 1 AWG
Long motor cycles (double deck, power down)	50 mm ² - 0 (1/0) AWG

- Batteries and their charging system should be chosen to comply with following minimum requirements:

	Voltage System					
	12V			24V		
Tail lift capacity (lb / kg)	Electrical power (Amp)	Battery capacity (Ah)	Generator output (A)	Electrical power (Amp)	Battery capacity (Ah)	Generator output (A)
≤ 1750 / 800	200	143	70	150	105 (2X)	70
≤ 2200 / 1000	250	143	70	200	105 (2X)	70
≤ 3300 / 1500	250	180	90	200	180 (2X)	90
> 3300 / 1500	250	180	110	250	180 (2X)	110
> 3300 / 1500 Freq. Usage	300	220	110	300	220 (2X)	110

NOTICE

- To ensure the reliability of the tail lift over many years, it is extremely important that the batteries, their charging system, the (+) battery and (-) ground cables, fuses and circuit breakers are dimensioned sufficiently strong, and fitted with care following DHOLLANDIA installation instructions. Insufficient battery power will cause harm and irreparable damage to the electric components of the tail lift (starter solenoid, electric motor, electric switches, etc...).
- Insufficient cable gauge on the (+) battery and (-) ground cables can lead to overheating, bad performance of the electrical system, and premature wear of the main electrical components.
- (-) ground circuits are as important as (+) battery circuits for the good operation of the tail lift, but often overlooked in troubleshooting. Make sure you take these into consideration when executing repairs or maintenance checks.

- DHOLLANDIA mainly uses 2 types of oils in its hydraulic systems:

1. Standard oil: ISO VG 22.

This common and widely available hydraulic oil is used in the majority of DHOLLANDIA lifts, sold for use in "normal" climate conditions. This includes all countries excluding the Nordic countries suffering very cold winter climate. Refer to the product specifications of Q8 - Haydn ISO VG 22 (*) attached for further technical details.

2. Option OAH002 (old ref. S502) = arctic oil -52°C: mineral low-temperature hydraulic fluid

This option is used on lifts sold to countries subjected to very cold freezing temperatures during winter, including Russia, Ukraine, the Baltic states, Poland, Scandinavia, Canada. Refer to the product specifications of Castrol - Aero HF 585 B (*) attached for further technical details.

NOTICE

It is important to follow these guide-lines with due care. A lot of oils or fluids used in automotive industry, such as transmission fluids and ATF oils, are not suitable for tail lift use. DHOLLANDIA has not tested the potential consequences of oils and fluids with deviating specifications and cannot be held responsible or legally liable for any damage to the tail lift caused by the replenishment with non-compatible oils or fluids; nor for the consequential damage to property or physical harm to individuals.

19.9 END NOTE

- DHOLLANDIA would like to thank you for using our products and leave you with this final notice and warning.
- Additional information about this tail lift and many other DHOLLANDIA products is available at the following link:
<http://www.dhollandia.com>

NOTICE

- Competent and regular preventative maintenance is essential to the operational reliability and safety of the operator or bystanders.
- All maintenance and repair work should be performed by authorized DHOLLANDIA service agents.
- Only authorized OEM DHOLLANDIA replacement parts should be used for all repairs.
- Consult the separate MAINTENANCE AND REPAIR MANUAL for safety instructions, maintenance guidelines, and troubleshooting support.



WARNING

- Improper use of the tail lift may result in damage, premature wear or failure of the tail lift, and will increase the risk of serious injury or death to the operator or bystanders.
- To maximize the durability, ensure long-term reliability of the tail lift, and protect operators and bystanders from serious bodily injury or death, the operator **MUST** comply with the proper loading instructions and safe working procedures in the OPERATIONS MANUAL.

Type : DH-R* + Power Down [DAD4] + OAE015.PR - 2017/...

Power pack :

Valve : V191.B + V197

Plan N° : wd_RP-DAD4-OAE015.PR-2017-01

Date : 06/06/2017

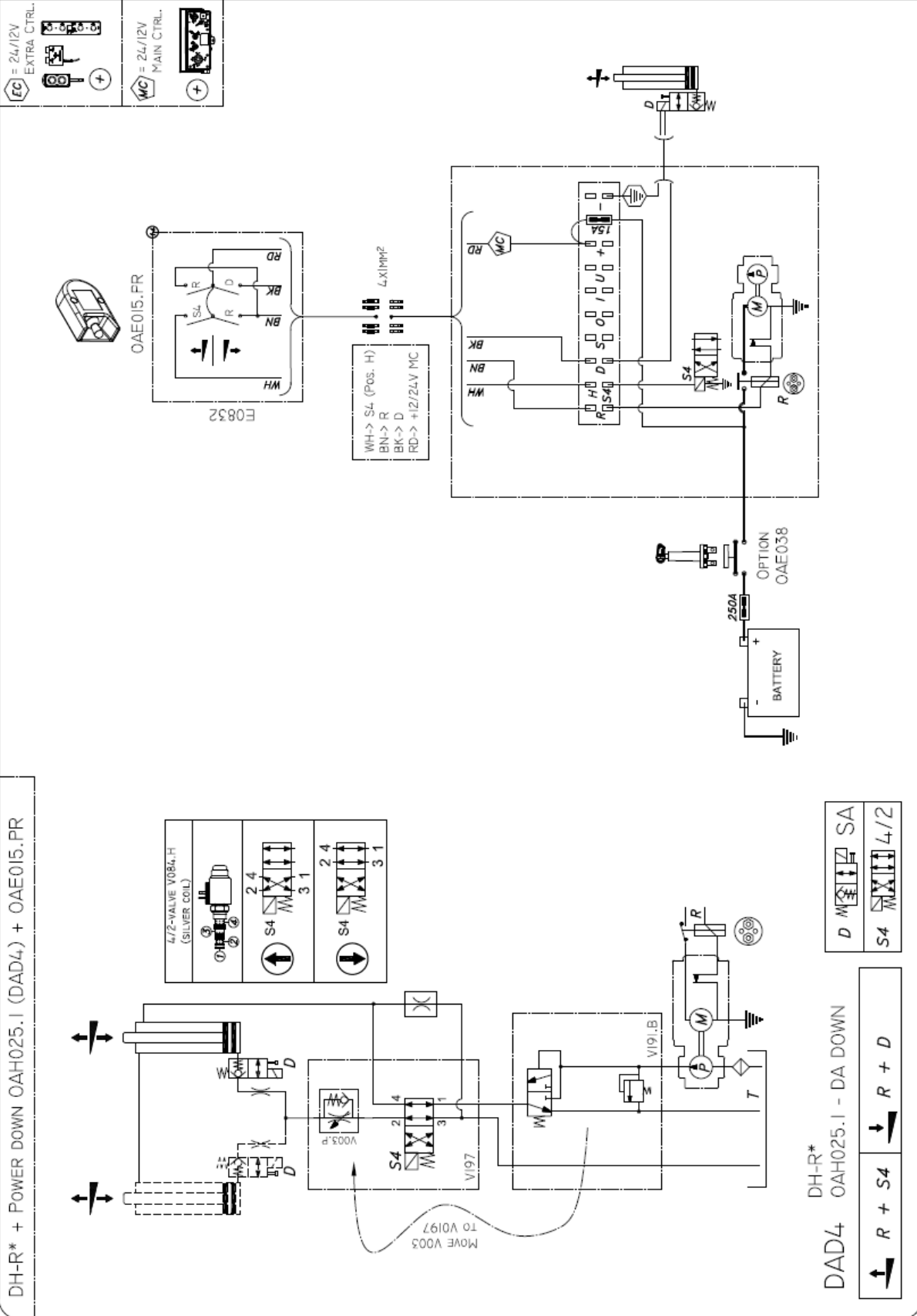

DH-R* + POWER DOWN OAH025.1 (DAD4) + OAE015.PR

DH-R*
DAD4 OAH025.1 - DA DOWN

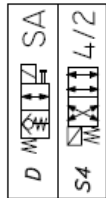
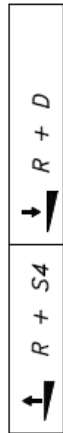

Type : DH-R* + Power Down [DAD4] + OAE015.PR + OAE503.1 - 2016/...

Power pack :

Valve : V191.B + V197

Plan N° : wd_RP-DAD4-OAE015.PR-OAE503.1-2016-01

Date : 16/12/2016

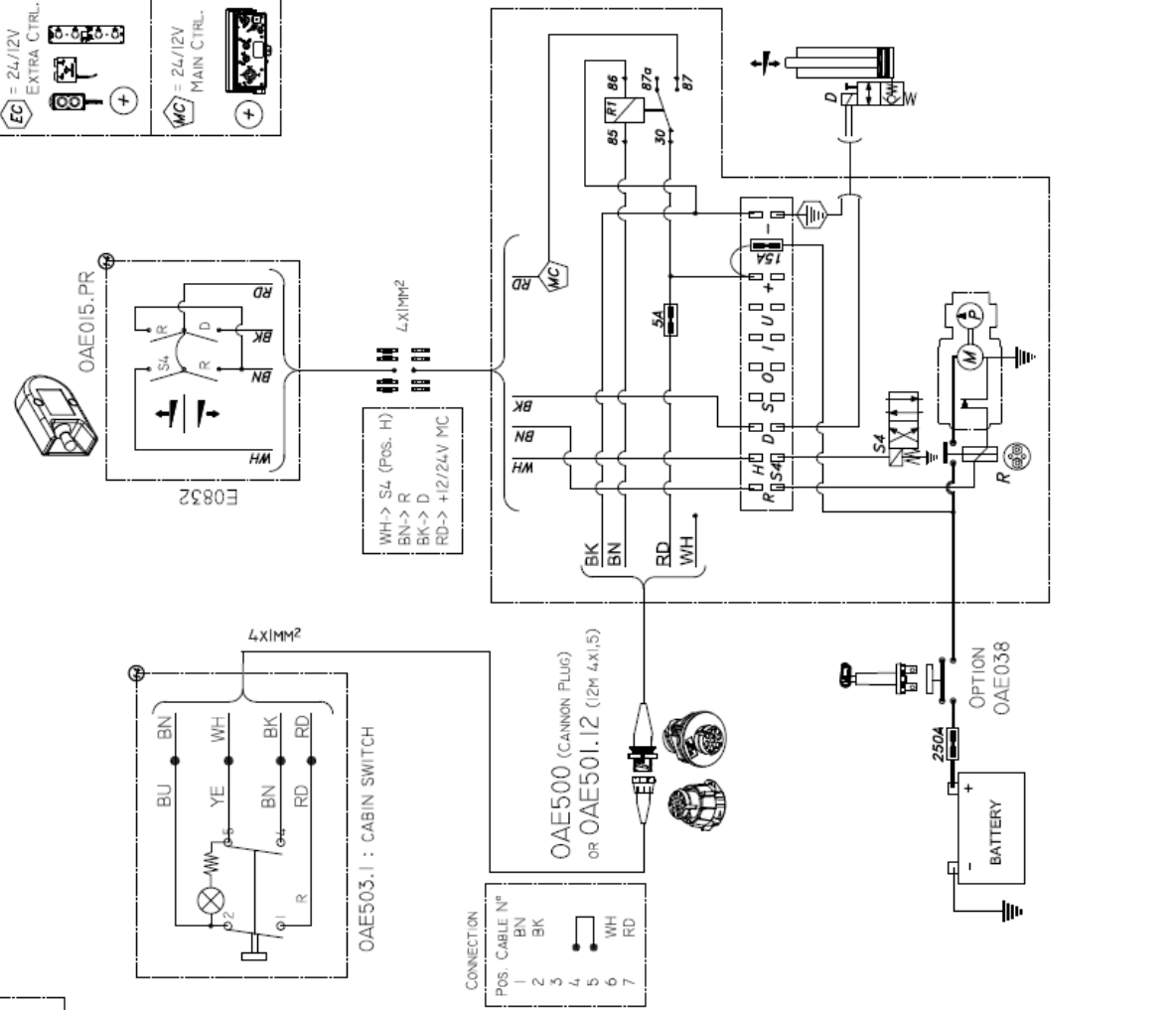

DH-R* + POWER DOWN OAH025.1 (DAD4) + OAE015.PR + OAE500 / OAE501.LE + OAE503.1

