



→ Side-mounted slider lift for trucks

## DH-SO(C)Z.10 • 750 - 1000 kg



The DH-SOZ.10 replaces the fold-away lift DH-REK.10 after more than 30 years of duty, and various upgrades. It is mounted on truck chassis, in front of the rear axle, and is used to **unload or load goods at the side doors** of the truck body.

Unlike many regular fold-away lifts, the DH-SOZ.10 is **suitable for refrigerated bodies** with an insulated floor. It is often used in the **food distribution, to deliver frozen or chilled food** product into chain restaurants.

The DH-SOZ.10 is equipped with a double folded platform and a bespoke lift frame construction, to fit within the available mounting space at the side of the truck. In comparison to the former DH-REK.10, this modern slider lift offers a huge improvement in **handling ease, operation and ergonomics**.

### Lift capacity

CAP	CG	LM
750 kg	600 mm	3.6 kNm
1000 kg	600 mm	6 kNm

### Weights [see pg. 19]

ALU / ALU	
1150 mm	315 kg
1350 mm	325 kg

# Compact slider lift for use at the side doors

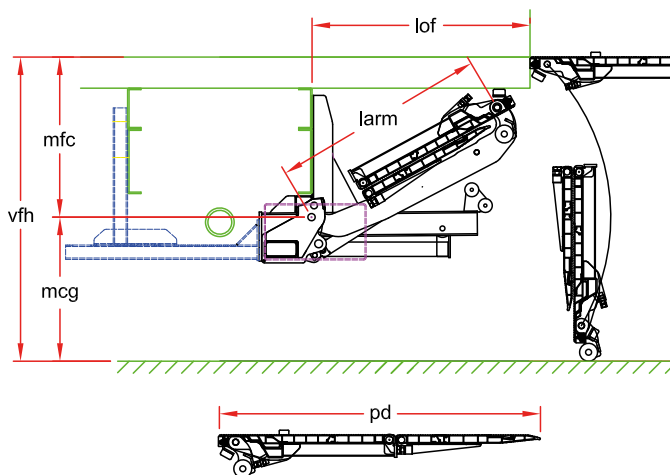

## Fitting dimensions

<b>larm</b>	<b>900</b>
vfh max.	1400
mfc max.	715
mcg max.	685
lof	study req.
pd max.	1350



## Technical specifications

Lift frame	Custom made lift frame, adapted for side mounting on truck chassis
Cylinders	<ul style="list-style-type: none"> <li>• 2 lift cylinders + 2 fixed stabilizers</li> <li>• 2 tilt cylinders available as option [OAH036]</li> </ul>
Retraction IN / OUT	Centrally mounted retraction cylinder
Type of ride [see pg. 8-9]	Wedged platform. Level ride + automatic tilt at ground level
Platform material	Alu / Alu
Standard platform depths	1150 - 1350 mm
Standard platform widths	1600 mm Other widths on request [OAP603]
Lift arm length	900 mm
Lift arm width	700 mm
Std. control unit [see pg. 10]	OAE030.BT
Standard finish of the lift frame	Hot-dip zinc plated finish [OAT104]