



→ Passenger lift for midibuses & coaches

DH-CH103.05 • 350 - 500 kg



The **DH-CH103** are **heavier-duty** cassette lifts up to max. 500 kg lift capacity, usually mounted in the **luggage compartment**, or **integrated in the stairs** at the middle or front door(s) of M3 buses and coaches.

This lift is equipped with a **single-piece platform** to eliminate as many moving parts as possible and reduce maintenance needs.

The DH-CH103 offers excellent platform stability and guarantees superior reliability in service.

Cassette lift mounted in luggage compartment or in stairs

Weights [see pg. 19]

Steel / Alu	
CH103	270 kg

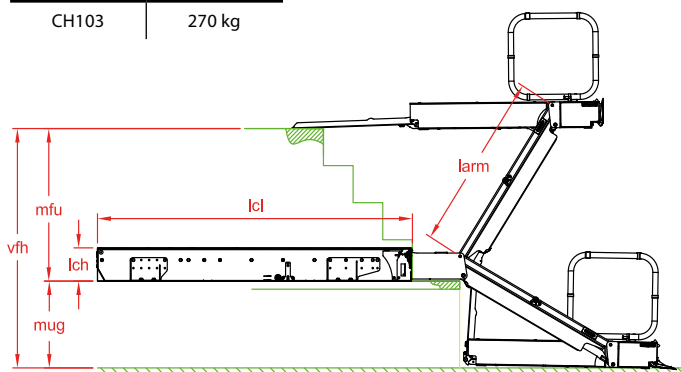

Fitting dimensions

Type	larm	CAP kg	mug max.	lch	lcl	mfu min.	mfu max.	vfh max.
CH103.04.02	1100	450	535	200	2000	485	940	1475
CH103.03.02	1300	350	640	200	2200	590	1160	1800
CH103.05.02	1280	500	620	200	2000	610	1150	1770

Technical specifications

Lift frame	2 lift arms
Cylinders	2 lift cylinders
Retraction in / out	Electric motor + gear wheel system
Type of ride [see pg. 8-9]	Flat platform, level ride
Standard platform dimensions	1200 x 800 mm (LxW)
Platform details	<ul style="list-style-type: none"> Aluminium platform with anti-slip surface Solid single-piece platform Automatic roll-stop at the outboard platform edge Automatic bridge plate to the vehicle floor
Safety rails	2, left & right, folding manually
Std. control unit	OWE008.2
Standard finish of the lift frame	KTL epoxy e-coating