



→ Tail lift for factory built panel vans

DH-P1.03 • 300 kg



The DH-P1 is a single-arm lift, suitable for mounting inside the rear or side doors of a wide range of factory built panel vans.

In its standard configuration, the DH-P1 has its travel position just inside the doors of the vehicle. As an option, it can be equipped with an articulated frame [option OWU006], that allows to stow the platform against the side of the body and keeps the access through the vehicles doors free.

The platform is flat, so that goods, such as roll-cages, white & brown goods, small machinery,..., can be loaded with minimal effort.

The DH-P1 can be mounted at the rear doors or at the side door; at the left or right side in the door aperture.

Option OWU007

(Cannot be combined with option OWU006)

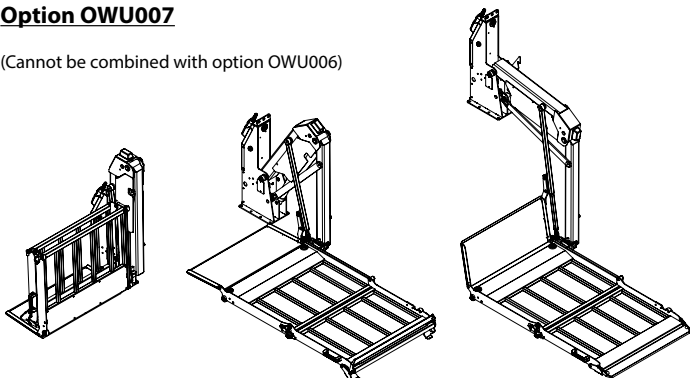

Step-in model, easy to use and flexible

OWU006 in travel position
mounted right side

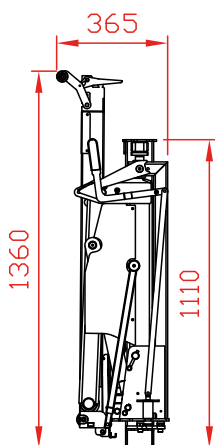

OWU006 in work position
mounted right side

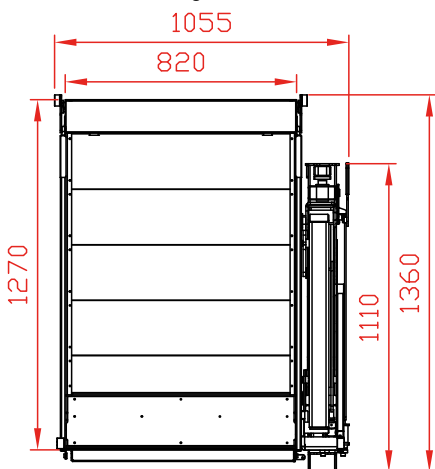

Lift capacity

CAP	CG	LM
300 kg	500 mm	1.5 kNm

Weights [see pg. 19]

	Standard	OWU006
	1260 mm	139 kg

Fitting dimensions

larm	600	700 (*)
vfh max.	700	950

(*) optional

Technical specifications

Lift frame	<ul style="list-style-type: none"> • 1 lift arm • Standard = fixed frame. The closed platform stands in the door aperture • Option OWU006 = rotating frame. The platform can be swung out of way to a travel position against the side of the body • Option OWU007 = fixed frame with a 1200 mm foldable platform
Cylinders	1 lift cylinder
Type of ride [see pg. 8-9]	Flat platform, level ride
Platform material	Steel frame + aluminium profiles
Platform equipment	<ul style="list-style-type: none"> • Automatic roll-stop at the outboard platform edge • Automatic bridge plate and toe-guard at the inboard platform edge
Standard platform depths	<ul style="list-style-type: none"> • 1080 - 1170 - 1260 mm standard • 1200 mm for OWU007 • Other depths on request [OWP002.L]
Standard platform widths	820 mm standard / 720 mm optional [OWP002.W]
Std. control unit [see pg. 11]	OAE001
Standard finish of the lift frame	Protection PLUS [OAT102]