



→ Lift for vans, trucks, trailers and semi-trailers

DH-P2.07 • 750 kg



The DH-P2.07 is DHOLLANDIA's **most powerful internally mounted lift**. It offers:

- a **heavier-duty lift mechanism** with 500-750 kg lift capacity (subject to vehicle restrictions. Ask our advice)
- **larger platforms** up to 1600 mm long and 920 mm wide
- **increased lifting height** up to 1150 mm.

Hence, the DH-P2.07 is not only designed for factory built panel vans, but also suits larger trucks, trailers and semi-trailers.

The heavy-duty twin-arms lift is available in 2 executions: a standard full-closure platform; and a vertical split platform [option OWU002].

Standard

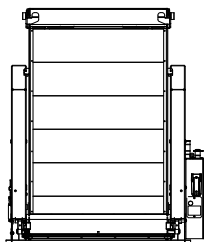

Option OWU002

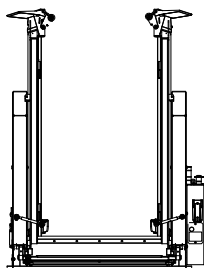

Heavy duty 750 kg internally mounted twin-arms lift

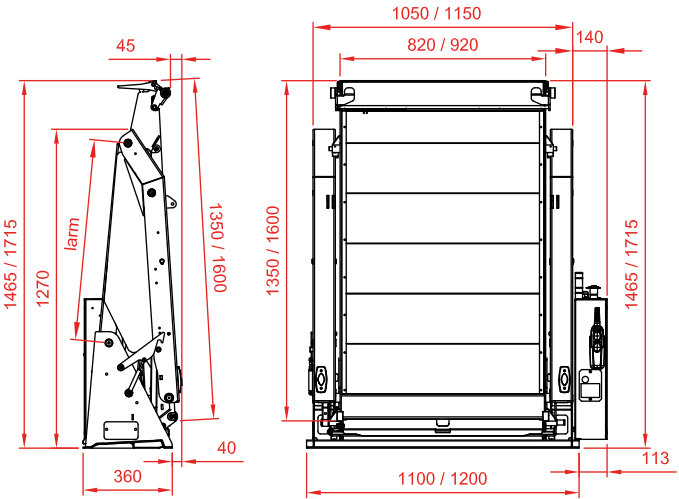

Lift capacity

CAP	CG	LM
750 kg	500 mm	3.75 kNm

Weights [see pg. 19]

Alu platform	
1350 x 820	180 kg
1600 x 920	190 kg
OWU002	+15 kg

Fitting dimensions

larm	800
vfh max.	1150

Technical specifications

Lift frame	Reinforced lift frame with 2 lift arms
Cylinders	2 lift cylinders
Type of ride [see pg. 8-9]	Flat platform, level ride
Platform material	Steel frame + aluminium profiles
Platform equipment	<ul style="list-style-type: none"> Automatic roll-stop at the inboard platform edge Automatic bridge plate and toe-guard at the outboard platform edge
Standard platform depths	1350 - 1600 mm Other depths on request [OWP002.L]
Standard platform widths	820 mm standard / 920 mm optional [OWP002.W]
Std. control unit [see pg. 11]	OAE001
Standard finish of the lift frame	Protection PLUS [OAT102]